

Network Connectivity

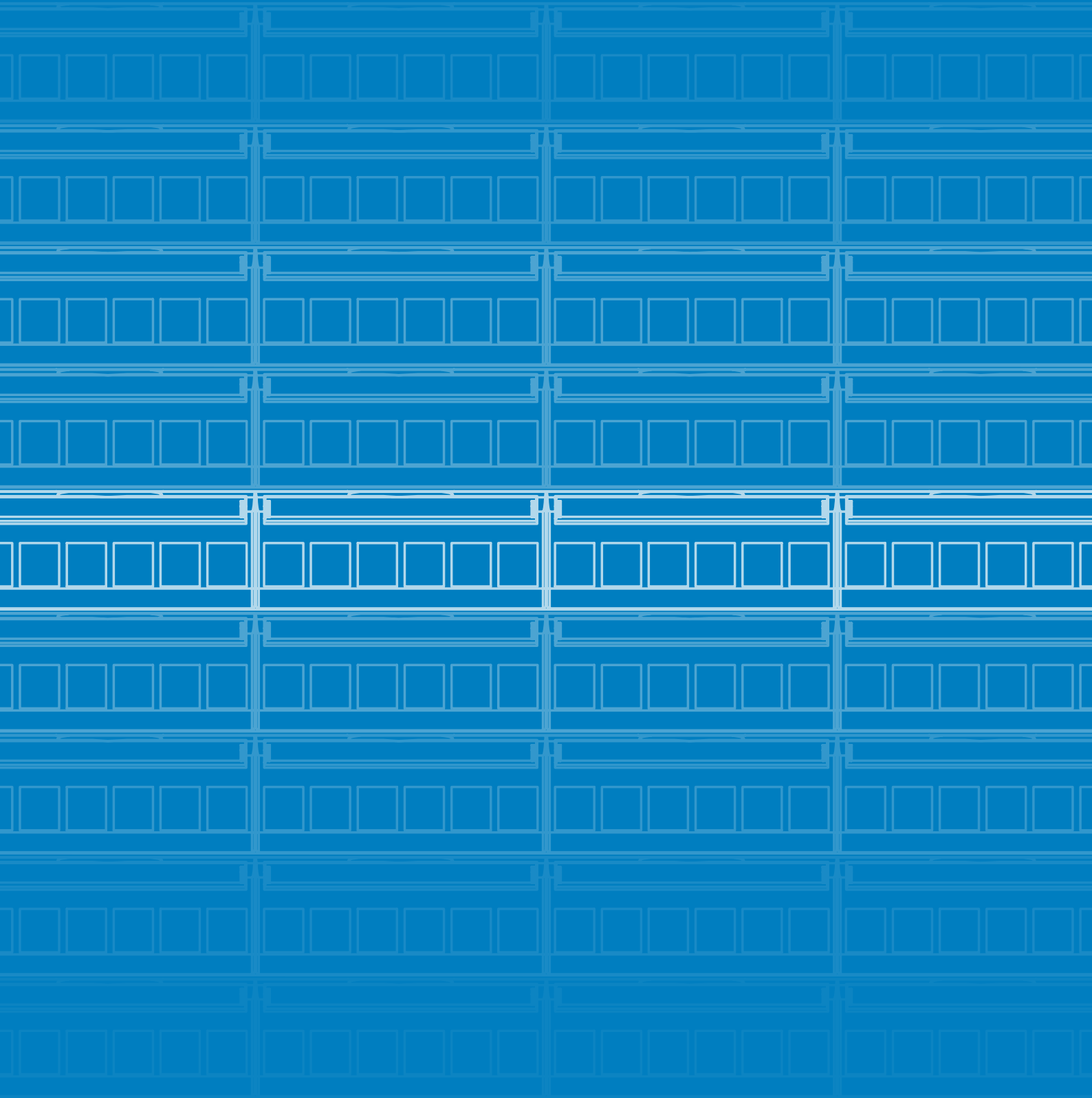

Content

Copper Solution	p1
Fiber Solution	p19
Technical Information	p29
Glossary	p37

Copper Solution

Category 6 UTP Cable

Digilink Category 6 UTP cable consists of 100-Ohm impedance, 4 pair UTP cables for horizontal installations in local area networks (LANs). All cables meet and exceed Category 6/Class E requirements in ANSI/TIA-568-C.2, and ISO/IEC 11801.

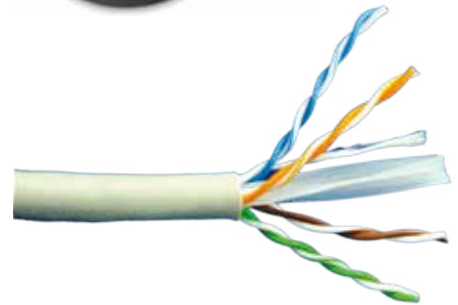
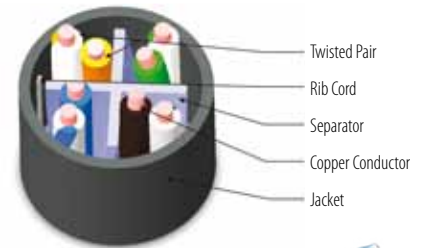

MECHANICAL SPECIFICATIONS

Outer Diameter	Nominal diameter 6.0mm 4 twisted pair
Conductor Type	23 AWG bare solid copper
Jacket Material	PVC
Standard Colour	Grey

ELECTRICAL SPECIFICATIONS

Characteristic Impedance	100±6 Ω@ 1-300 Mhz
DC Resistance	72 Ω/km (max)
Voltage Rating	72 Vdc max
Dielectric Strength	1500 V/1 minute min rms
Insulation Resistance	500MΩ/km(min)@500 Vdc
Velocity of Propagation (NVP)	69%

PRODUCT FEATURES

- Exceptional material properties and cable design
- High ACR values-providing low BER (Bit Error-Rate)
- Extremely high pair-balance-providing excellent EMC (Electromagnetic compatibility)
- Minimum radiations and maximum noise immunity
- Unique hologram sticker for authenticity
- UL94V-0 rated plastic
- RoHS Compliant
- UL/ETL Verified, UL listed
- ANSI/TIA-568-C.2 Category 6

PERFORMANCE CHARACTERISTICS ANSI/TIA-568-C.2 (HORIZONTAL CABLE)

Frequency (MHz)	Return Loss (dB)	Attenuation (dB/100m)	NEXT (dB)	ACR (dB)	PSNEXT (dB)	ELFEXT (dB)	PSELFEXT (dB)	Delay (ns/100m)
1	20.0	2.0	74.3	72	72.3	67.8	64.8	570
4	23.0	3.8	65.3	61	63.3	55.8	52.8	552
8	24.5	5.3	60.8	55	58.8	49.7	46.7	547
10	25.0	6.0	59.3	53	57.3	47.8	44.8	545
16	25.0	7.6	56.2	49	54.2	43.7	40.7	543
20	25	8.5	54.8	46	52.8	41.8	38.8	542
25	24.3	9.5	53.3	44	51.3	39.8	36.8	541
31.25	23.6	10.7	51.9	41	49.9	37.9	34.9	540
62.5	21.5	15.4	47.4	32	45.4	31.9	28.9	539
100	20.1	19.8	44.3	25	42.3	27.8	24.8	538
150	18.9	24.7	41.7	16.9	39.7	24.3	21.3	537
200	18.0	29.0	39.8	10.8	37.8	21.8	18.8	537
250	17.3	32.8	38.3	5.5	36.3	19.8	16.8	536

NUMBER	DESCRIPTION
DC6CAUTP4P1X	Category 6, 4 Pair UTP Cable 100m
DC6CAUTP4P3X	Category 6, 4 Pair UTP Cable 305m

Note: This cable is used for low Voltage signal transmission used in IT industry

Category 5e UTP Cable

Digilink Category 5e UTP cable consists of 100-Ohm impedance, 4 pair UTP cables for horizontal installations in local area networks (LANs). All cables meet and exceed Category 5e Class D performance requirements in ANSI/TIA-568-C.2 and ISO/IEC 11801 standards.

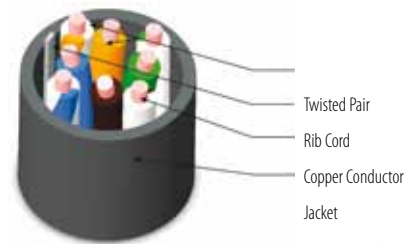

MECHANICAL SPECIFICATIONS

Outer Diameter	Nominal diameter 5.1mm 4 twisted pair
Conductor Type	24 AWG bare solid copper
Jacket Material	PVC
Standard Colour	Grey

ELECTRICAL SPECIFICATIONS

Characteristic Impedance	100±6 Ω@ 1-100 Mhz
DC Resistance	72 Ω/km (max)
Voltage Rating	72 Vdc max
Dielectric Strength	1500pF/km max. @ 1 KHz
Insulation Resistance	500MΩ/km(min)@500 Vdc
Velocity of Propagation (NVP)	69%

PRODUCT FEATURES

- Exceptional material properties and cable design
- High ACR values-providing low BER (Bit Error-Rate)
- Extremely high pair-balance-providing excellent EMC (Electromagnetic compatibility)
- Minimum radiations and maximum noise immunity
- Unique hologram sticker for authenticity
- UL94V-0 rated plastic
- RoHS Compliance
- UL/ETL Verified, UL listed
- ANSI/TIA-568-C.2 Category 5e
- ISO/IEC-11801 (2nd edition) Class D

PERFORMANCE CHARACTERISTICS ANSI/TIA-568-C.2 (HORIZONTAL CABLE)

Frequency (MHz)	Return Loss (dB)	Attenuation (dB/100m)	NEXT (dB)	ACR (dB)	PSNEXT (dB)	ELFEXT (dB)	PSELFEXT (dB)	Delay (ns/100m)
0.772	19.4	n/s	n/s	n/s	n/s	n/s	n/s	n/s
1	20.0	2.0	65.3	63	62.3	63.8	60.8	570
4	23.0	4.1	56.3	52	53.3	51.7	48.7	552
8	24.5	5.8	51.8	46	48.8	45.7	42.7	547
10	25.0	6.5	50.3	44	47.3	43.8	40.8	545
16	25.0	8.2	47.3	39	44.3	39.7	36.7	543
20	25.0	9.3	45.8	37	42.8	37.7	34.7	542
25	24.3	10.4	44.3	34	41.3	35.8	32.8	541
31.25	23.6	11.7	42.9	31	39.9	33.9	30.9	540
62.5	21.5	17.0	38.4	21	35.4	27.8	24.8	539
100	20.1	22.0	35.3	13	32.3	23.8	20.8	540

NUMBER	DESCRIPTION
DCECAUTP4P1X	Category 5e, 4 Pair UTP Cable 100m
DCECAUTP4P3X	Category 5e, 4 Pair UTP Cable 305m

Note: This cable is used for low Voltage signal transmission used in IT industry.

Multipair Cable

Digilink multipair cables are designed to provide a cost effective and simple way to feed PBX or other simple voice circuits into a structured cabling system. The products are available in kits or as individual add on components. This multipair LAN cable consists of 24AWG solid copper conductors insulated with colour-coded polyolefin and jacketed with strong fire retardant PVC. It is general purpose, high performance cable used in voice and LAN applications.

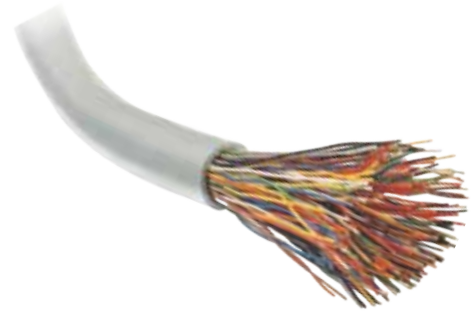

MECHANICAL SPECIFICATIONS

Conductor Type	24 AWG
Insulation Thickness	0.20 mm (nominal)
Jacket Thickness	0.75 mm (nominal)
Breaking Pulling Force	40 N/conductor

ELECTRICAL SPECIFICATIONS

Nominal Velocity of Propagation (NVP)	69%
Maximum Resistance	9.40/100m(DC)
Mutual Capacitance @ 1 KHz	59 pF/m
Max Capacitance Unbal(Pair to ground)	3.28 pF/m

PRODUCT FEATURES

- Exceptional material properties and design
- Integrity
- TIA/EIA 568A (1995)
- RoHS Compliant
- ISO/IEC 11801 (1995)
- Data, telecommunication, voice & low voltage system applicable

NUMBER	DESCRIPTION
DXCAT5UT25P	Category 5, 25 Pair UTP Cable 305m
DXCAT3UT25P	Category 3, 25 Pair UTP Cable 305m
DXCAT3UT50P	Category 3, 50 Pair UTP Cable 305m
DXCAT3UT100P	Category 3, 100 Pair UTP Cable 305m

Category 6, UTP 24-Port Patch Panel

Digilink Category 6 UTP 24-port patch panel is an array of jacks, typically rack mounted, that houses cable connections. One normally shorter patch cable will be plugged into the front side, while the back will hold the connection of a much longer and more permanent cable. The assembly of hardware is arranged so that a number of circuits, usually of the same or similar type appear on jacks for monitoring, interconnecting, and testing circuits in a convenient and flexible manner. Patch panels offer the convenience of allowing technicians to quickly change the path of selected signals without the expense of dedicated switching equipment.



MECHANICAL SPECIFICATIONS

Size	482.6mm x 44.2 (19" x 1U)
Panel Material	Steel-fully powder coated
Conductor Compatibility	22-26AWG solid cable
Spring Contact	Phosphor bronze 50µ" gold over 100µ" nickel plating
Unshielded	RJ 45
Plug Insertion Cycle	750 times
Bezel	High impact flame retardant plastic

ELECTRICAL SPECIFICATIONS

DC Resistance	72Ω max
Contact Resistance	20 mΩ (max) per contact
Voltage Rating	72 Vdc max
Dielectric Strength	1000 V rms for 1 minute min
Insulation Resistance	500MΩ(min)@500 Vdc
Current Rating	1.5A max

PRODUCT FEATURES

- Innovative design metal panel making it robust & sleek
- Keystone designed to snap in & out easily
- Clear label window for port identification
- RoHS Compliant
- UL/ETL Verified, UL listed
- ISO/IEC-11801 Class E
- ANSI/TIA-568-C.2 Category 6
- EIA/TIA TSB 40 A

NUMBER	DESCRIPTION
DC6PP24UKY1U	Category 6, UTP 24-Port Patch Panel, Loaded

Category 5e, UTP 24-Port Patch Panel

Digilink Category 5e UTP 24-port patch panel comes with a design, which has redefined engineering elegance. It is a three piece structure that includes the front panel, the metal case and the cable management plate. The cable management plate comes with pre-fitted B-Clip that helps in routing cables and provides a perfect strain relief. The front plate has icon holders which help identify the media used such as computer, telephone, etc.



MECHANICAL SPECIFICATIONS

Size	482.6 x 44.2 (19" x 1U)
Panel Material	Steel-fully powder coated
Conductor Compatibility	22-26AWG solid cable
Spring Contact	Phosphor bronze 50µ" gold over 100µ" nickel plating
Mating Cycles	750 cycles

ELECTRICAL SPECIFICATIONS

Contact Resistance	20mΩ (max) per contact
Voltage Rating	72 Vdc max
Dielectric Strength	100 V rms for 1 minute min
Insulation Resistance	500MΩ(min)@500 Vdc
Current Rating	1.5A max

PRODUCT FEATURES

- Elegant rear cable manager with built connector case
- Light weight and compact design
- Keystone designed to snip in & out easily
- Clear label window for port identification
- The keystone comes with T568A or T568B wiring and fully complies with ANSI/TIA/EIA-568-B Category 5e
- RoHS Compliant
- UL/ETL Verified
- ISO/IEC-11801
- ANSI/TIA-568-C.2 Category 5e
- EIA/TIA TSB 40 A

NUMBER	DESCRIPTION
DCEPP24UKY1U	Category 5e, UTP 24-Port Patch Panel, Loaded

Category 6, UTP 24-Port Patch Panel, Half U

Digilink patch panel is an array of 8P 8C connectors, typically rack mounted that houses cable connections. One normally shorter patch cable will be plugged into the front side, while the back will hold the connection of a much longer permanent cable. Patch panels offer the convenience of allowing technicians to quickly change the path of select signals, without the expense of dedicated switching equipment. Specially designed in half "U" size to save space in rack.



MECHANICAL SPECIFICATIONS

Size	482.6 x 22.1 (19" x 0.5U)
Panel Material	Steel-fully powder coated
Connector	IDC-22-26AWG solid cable
Spring Contact	Phosphor bronze 50µ" gold over 100µ" nickel plating
Housing	High impact flame retardant plastic
Plug Insertion Life	750 cycles

ELECTRICAL SPECIFICATIONS

Contact Resistance	20mΩ (max) per contact
Voltage Rating	72 Vdc max
Dielectric Strength	1000 V rms for 1 minute min
Insulation Resistance	500MΩ(min)@500 Vdc
Current Rating	1.5A max

PRODUCT FEATURES

- Modular design for termination of horizontal & backbone cabling
- 8 port modular tray unit assembly
- The PCB design combines advanced balancing methodology with pair isolation technique used in IDC blocks
- ISO/IEC-11801, Class E
- ANSI/TIA-568-C.2
- EIA/TIA TSB 40 A
- RoHS Compliant
- EN 50173 2nd Edition

NUMBER	DESCRIPTION
DC6PP24UKRHU	Category 6, UTP 24-Port Patch Panel, Loaded, 0.5U

Category 6, UTP 24-Port Patch Panel, Die Cast

Digilink's patch panels has redefined compact post management yet again. It has patented die cast aluminium design. Aluminium die cast body provides very high strength to weight ratio, extremely robust one can literally climb over it. Head to head jack assembly allows caste management is in rear side.



MECHANICAL SPECIFICATIONS

Mounting	1U, 19" rack mountable
Dimensions	482mm x 44mm /88mm
-	Die Cast aluminium construction

PRODUCT FEATURES

- Unique stragering jack alignment and metal separators provide excellent NEXT and AXT performance
- Occupies 1U only (44.5mm)
- 24 Port Die Cast aluminium construction
- Unique label holder magnifies port label for easy and fast identification
- Sturdy and wide aluminium die cast cable manager allows ease in cable routing
- When installed in a "Total Availability Network", these patch panels can deliver uninterrupted data at high speeds
- Die cast unique design with rear cable manager

NUMBER	DESCRIPTION
DC6PP24UKY1UB	Category 6, UTP 24-Port Patch Panel, Unloaded, Die Cast

Cable Management Panel

Digilink cable management panels are designed to accompany patch panel on to the 19" standard rack and accommodate large bundles of cable organized.



MECHANICAL SPECIFICATIONS

Mounting	Mounted on standard EIA 19" racks
Size	1U - 44.2mm x 482.6mm (1.73" x 19") 2U - 88.4mm x 482.6mm (3.5" x 19")
Metal Panel Plate Colour	Black
Plastic Cable Hanger x Snos	Black
-	Plastic cable hanger screwed to the panel

PRODUCT FEATURES

- Available in 1U and 2U
- Light weight and compact design
- Available in black colour
- Design for easy and manageable cable routing
- Adjustable plastic clips, in all required directions
- Flexible plastic clip for easy access
- RoHS Compliant

NUMBER	DESCRIPTION
DXYHCM19XX1U	1U Cable Management Panel
DXYHCM19XX2U	2U Cable Management Panel

110 Cross Connect Kit

Digilink 110 patch panel comes with 100 pair set. It includes 5 pair and 4 pair IDC connecting blocks. These connectors use premium grade phosphor bronze contacts suitably plated for long life. These contacts are specially designed to accommodate solid wire as well as stranded conductors from 22 to 26 AWG. Index Strip mounted on 19"(483mm) wide panel having 1U standard height dimensions. Plastic components are fire retardant, confirming to UL 94 V-0 safety rating.



MECHANICAL SPECIFICATIONS

Height	2U Standard height
Width	483mm (19 in)
Depth	75mm (2.95 in)
Contact Material	Phosphor bronze
Plastic Components	Polycarbonate IDC

ELECTRICAL SPECIFICATIONS

Maximum Resistance	9.40/100m(DC)
Mutual Capacitance @ 1 KHz	59 pF/m
Max Capacitance Unbal (Pair to ground)	3.28 pF/m

PRODUCT FEATURES

- Exceptional material properties and design
- Integrity
- TIA/EIA 568A (1995)
- RoHS Compliant
- ISO/IEC 11801 (1995)

NUMBER	DESCRIPTION
DXYCXTW100R	110 Cross Connect Kit, 100 Pair with Cable Manager

Category 6 Modular Jack

Digilink Category 6 modular jack includes high performance Category 6 snap-in 8-position /8-contact (8P8C) jacks (Patent pending design) conforming to IEC 60603-7-2 (unshielded 100 MHz connectors). These jacks are designed for fast and easy snap-in and out of wall plates and patch panels. All jacks are designed in a 180° style and are available with back interconnection of 110 IDC blocks or special LSAPlus/110 IDC combination blocks in T568A, T568B.



MECHANICAL SPECIFICATIONS

Plug Retention Force	14Kgf (140N)
Plug Reliability	750 cycle minimum
Jack Contact Material	Phosphor bronze 50µ" gold over 100µ" nickel plating
Conductor Compatibility	22-26AWG solid cable
Standard Colour	Blue, White, Yellow
Jack Mating Life	750 cycles

ELECTRICAL SPECIFICATIONS

Voltage Rating	72 Vdc (max)
Propagation Delay	2.5ns Max @1-100 MHz
Contact Resistance	20 mΩ (max) per contact
Current Rating	1.5A max
Insulation Resistance	500MΩ(min)@500 Vdc

PRODUCT FEATURES

- Robust and installer friendly design
- Compatible with 22-26 AWG solid cables
- Compatible to T568A, T568B wiring pattern
- Jacks with 180° from design-provide easier access
- UL-94V0 rated plastics
- ANSI/TIA-568-C.2 Category 6
- CENELEC EN 50173 & ISO/IEC-11801, Class E
- RoHS Compliant
- ETL Verified

NUMBER	DESCRIPTION
DC6KYSTUWT	Category 6, UTP Keystone, Modular Jack, White
DC6KYSTUBL	Category 6, UTP Keystone, Modular Jack, Blue
DC6KYSTUYL	Category 6, UTP Keystone, Modular Jack, Yellow

Category 5e Modular Jack

Digilink Category 5e modular jack includes high performance snap-in modular 8-position/8-contact (8P8C) jacks conforming to IEC 60603-7-2 (unshielded 100 MHz connectors). They are designed for fast and easy snap-in and out of wall plates and patch panels. All jacks are designed in a 180° form and are available with back interconnection of 110 IDC blocks.

MECHANICAL SPECIFICATIONS

Plug Retention Force	14Kgf (140N)
Plug Reliability	750 cycle minimum
Jack Contact Material	Phosphor bronze 50µ" gold over 100µ" nickel plating
Conductor Compatibility	22-26AWG solid cable

ELECTRICAL SPECIFICATIONS

Voltage Rating	72 Vdc (max)
Propagation Delay	2.5ns Max @1-100 MHz
Contact Resistance	20 mΩ (max) per contact
Current Rating	1.5A max
Insulation Resistance	500MΩ(min)@500 Vdc



PRODUCT FEATURES

- Robust and installer friendly design
- Compatible with 22-26 AWG solid cables
- Compatible to T568A, T568B wiring pattern
- Jacks with 180° from design-provide easier access
- UL-94V0 rated plastics
- RoHS Compliant
- UL/ETL Verified, UL listed
- ANSI/TIA-568-C.2 Category 5e
- ISO/IEC-11801 Class D

NUMBER	DESCRIPTION
DCEKYSTUWT	Category 5e, UTP Keystone, Modular Jack, White
DCEKYSTUBL	Category 5e, UTP Keystone, Modular Jack, Blue
DCEKYSTUYL	Category 5e, UTP Keystone, Modular Jack, Yellow

Category 6 UTP Patch Cords

Digilink Category 6 UTP patch cords are assemblies of 4 twisted pairs 23 AWG stranded wire cables with modular plugs (superior three piece connector) crimped on both ends. T568A and T568B wiring schemes are both available. The premium category moulded boot gives a designer look and snag less feature.



MECHANICAL SPECIFICATIONS

Length	1,2,3 & 5m
Standard Colour	Blue, Grey, Yellow
Wiring	23 AWG stranded unshielded
Plug Material	Gold over nickel contacts
RJ45 Plug	Polycarbonate plug

ELECTRICAL SPECIFICATIONS

Current Rating	1.5A max
Insulation Resistance	500MΩ/km(min)@500 Vdc
Voltage Rating	72 Vdc max
Contact Resistance	15 mΩ (max) per contact

PRODUCT FEATURES

- Available in the lengths of 1, 2, 3 & 5 m
- Cat 6 unshielded twisted pair 100Ω stranded cable
- Multi strand and highly flexible
- HDPE insulation over conductors, PVC jacket all over
- Individual cable pair separated by a PE former
- UL94V-0 rated plastic
- RoHS Compliant
- UL/ETL verified, UL listed
- ANSI/TIA-568-C.2 Category 6
- ISO/IEC-11801 Class E

NUMBER	DESCRIPTION
DC6PCURJ01GYM	Category 6, Patch Cord, UTP, 1M, Grey
DC6PCURJ02GYM	Category 6, Patch Cord, UTP, 2M, Grey
DC6PCURJ03GYM	Category 6, Patch Cord, UTP, 3M, Grey
DC6PCURJ05GYM	Category 6, Patch Cord, UTP, 5M, Grey
DC6PCURJ01BLM	Category 6, Patch Cord, UTP, 1M, Blue
DC6PCURJ02BLM	Category 6, Patch Cord, UTP, 2M, Blue
DC6PCURJ03BLM	Category 6, Patch Cord, UTP, 3M, Blue
DC6PCURJ05BLM	Category 6, Patch Cord, UTP, 5M, Blue
DC6PCURJ01YLM	Category 6, Patch Cord, UTP, 1M, Yellow
DC6PCURJ02YLM	Category 6, Patch Cord, UTP, 2M, Yellow
DC6PCURJ03YLM	Category 6, Patch Cord, UTP, 3M, Yellow
DC6PCURJ05YLM	Category 6, Patch Cord, UTP, 5M, Yellow

Category 5e UTP Patch Cords

Digilink Category 5e UTP patch cords are electrical cables, used to connect ("patch in") one electronic device to another for signal routing. Patch cords are assemblies of 4 twisted pairs 24 AWG stranded wire cables with modular plugs crimped on both ends. T568A and T568B wiring schemes are both available.



MECHANICAL SPECIFICATIONS

Length	1, 2, 3 & 5 m
Standard Colour	Blue, Grey, Yellow
Wiring	24 AWG stranded
Plug Material	Gold over nickel contacts
RJ45 Plug	Polycarbonate plug

ELECTRICAL SPECIFICATIONS

Current Rating	1.5A max
Insulation Resistance	500MΩ/km(min)@500 Vdc
Voltage Rating	72 Vdc max
Contact Resistance	15 mΩ (max) per contact

PRODUCT FEATURES

- Available in the lengths of 1, 2, 3 & 5 m
- Cat 5e unshielded twisted pair 100Ω stranded cable
- UL94V-0 rated plastic
- RoHS Compliant
- UL/ETL Verified, UL listed
- ANSI/TIA-568-C.2 Category 5e
- ISO/IEC-11801 Class D

NUMBER	DESCRIPTION
DCEPCURJ01GYM	Category 5e, Patch Cord, UTP, 1M, Grey
DCEPCURJ02GYM	Category 5e, Patch Cord, UTP, 2M, Grey
DCEPCURJ03GYM	Category 5e, Patch Cord, UTP, 3M, Grey
DCEPCURJ05GYM	Category 5e, Patch Cord, UTP, 5M, Grey
DCEPCURJ01BLM	Category 5e, Patch Cord, UTP, 1M, Blue
DCEPCURJ02BLM	Category 5e, Patch Cord, UTP, 2M, Blue
DCEPCURJ03BLM	Category 5e, Patch Cord, UTP, 3M, Blue
DCEPCURJ05BLM	Category 5e, Patch Cord, UTP, 5M, Blue
DCEPCURJ01YLM	Category 5e, Patch Cord, UTP, 1M, Yellow
DCEPCURJ02YLM	Category 5e, Patch Cord, UTP, 2M, Yellow
DCEPCURJ03YLM	Category 5e, Patch Cord, UTP, 3M, Yellow
DCEPCURJ05YLM	Category 5e, Patch Cord, UTP, 5M, Yellow

110 Patch Cords

Digilink 110 patch cords are used as jumper cords or end-user patch cords. These patch cords come in 1 pair, 2 pair or 4 pair and have 110 to 110P, 110 to RJ45 plug. The connectors use premium grade phosphor bronze contacts suitably plated for long-life. These contacts are specially designed to accommodate solid wire as well as stranded conducts from 22 to 26 AWG.

MECHANICAL SPECIFICATIONS

Contact Material	Phosphor bronze
Plastic Components	Polycarbonate
Standard Colour	Grey

ELECTRICAL SPECIFICATIONS

Maximum Resistance	9.40/100m(DC)
Mutual Capacitance @ 1 KHz	59 pF/m
Max Capacitance Unbal (Pair to ground)	3.28 pF/m



DXYPC10101P01



DXYPC10102P01



DXYPC10104P01



DXYPC10RJ4P01

PRODUCT FEATURES

- Exceptional material properties and design
- Integrity
- TIA/EIA 568A (1995)
- RoHS Compliant
- ISO/IEC 11801 (1995)

NUMBER	DESCRIPTION
DXYPC10101P01	Category 5e, 1 Pair, 110-110 Patch Cord, 1m
DXYPC10RJ1P01	Category 5e, 1 Pair, 110-RJ45 Patch Cord, 1m
DXYPC10102P01	Category 5e, 2 Pair, 110-110 Patch Cord, 1m
DXYPC10RJ2P01	Category 5e, 2 Pair, 110-RJ45 Patch Cord, 1m
DXYPC10104P01	Category 5e, 4 Pair, 110-110 Patch Cord, 1m
DXYPC10RJ4P01	Category 5e, 4 Pair, 11 0-RJ45 Patch Cord, 1m

Modular Jack Termination Tools

The tools form an essential ingredient for any kit that is required by service personnel. The structured cabling system lays stress on following the practices which will add elegance, discipline, method and reliability to cabling. The tools which are used in installation of a cabling system go a long way in determining the above few characteristics.

Digilink offers 2 types of tools for Keystone jack termination: punch down tool and quick tool.

Punch down tool is an impact tool specially designed for punching 22-26 AWG wires. The impact pressures can be adjusted as per need, and blades are changeable to suit various types of connectors. The tool comes with dual 'BIT' suitable for '110' as well as 'Krone' type IDC (Insulation Displacement Contact). There also is an adjustment knob for 'Low' and 'High' impact.

Quick tool is specially designed for Digilink Keystone jacks. Simply press the wires into the Keystone IDC, and press the quick tool, termination and extra wire cutting can be done in just one step. Handle lock is provided as well for easy storage & transportation.

MECHANICAL SPECIFICATIONS

Material	High impact ABS
Tool Bit	Hardened steel



Punch Down Tool

PRODUCT FEATURES

- Exceptional material properties & design
- Suitable for 22-26 AWG wires
- Adjustable impact pressure, between low and high
- It comes with both 110 and Krone type of blades
- Sure lock blade holder
- RoHS Compliant
- EIA/TIA 568 A/B
- The tool bit can punch as well as trim the conductor



Quick Tool for Jack Termination

PRODUCT FEATURES

- Exceptional design
- Suitable for 22-26AWG wires
- Easy termination & extra wire cutting
- High efficiency even for not experienced installers
- Handle lock provided for transportation & storage
- RoHS Compliant
- EIA/TIA 568 A/B

NUMBER	DESCRIPTION
DXYTOOLPUNCH	Punch Down Tool
DXYTOOLQT	Quick Tool for Jack Termination

Crimping Tool

The tools form an essential ingredient for any kit that is required by service personnel. The structured cabling system lays stress on following the practices which will add elegance, discipline, method and reliability to cabling. The tools which are used in installation of a cabling system go a long way in and can sustain extensive use in the field. Digilink crimping tool can be used to crimp RJ-45 and RJ-11 types of connectors. It is a highly compact and rugged tool and is meant for continuous use in the field. The parallel action design maintains accurate.



MECHANICAL SPECIFICATIONS

Material	7.5 inch steel construction body
-	Suitable for 22-26 AWG wires
-	Ratchet mechanism

PRODUCT FEATURES

- Termination suitable for 8P, 6P, 4P connectors
- Equipped 8 P RJ-45, 6P RJ-12 & RJ-11 connectors
- Exceptional material properties & design
- Sure lock blade holder
- RoHS Compliant
- EIA/TIA 568 A/B

NUMBER	DESCRIPTION
DXYTOOLCRIMP	Crimping Tool
<i>Note: It is not recommended to terminate 8P8C (RJ-45) Plug on solid cable (Non Stranded conductor) as per EIA/TIA 568 B as well as ISO/IEC 11080 Standard.</i>	

Voice Impact & Punch Down Tool

The tools form an essential ingredient for any kit that is required by service personnel. The structured cabling system lays stress on following the practices which will add elegance, discipline, method and reliability to cabling. The tools which are used in installation of a cabling system go a long way in determining the above few characteristics. Digilink voice impact & punch down tool is designed for seating 5 pairs or 4 pairs of wires of 22-26 AWG into terminal block or cut off end after terminated at a time. These are suitable for both cross connect side and cable side terminal blocks. This tool is provided with a changeable and reversible heel block with blades, so as to use the tool for seating wires only as well as seating and cutting off wires at a time.



PRODUCT FEATURES

- EIA/TIA 568 A/B
- RoHS Compliant

MECHANICAL SPECIFICATIONS

Size	Size (L x B x H): 230 x 40 x 40
------	--

MATERIAL SPECIFICATIONS

Handle	Laminated with anti skid rubber
Punch	Hardened steel (housed in hard aluminium holder)
Surface treatment	Blackened to prevent rust

NUMBER	DESCRIPTION
DXYTOOLVP5P	Punch Down Tool 5 pair 110

Fiber Solution

Unitube, Light-Armoured Cables

Digilink Unitube light-armoured cable is constructed with jelly filled central tube. The buffer tubes are compatible with standard hardware, cable routing and fan-out kits. The construction provides ultimate strain relief to fibers in extreme installation service conditions. While all fibers are housed in central tube, strength is imparted by two FRP rods embedded in PE sheath. Corrugated steel armour makes it direct burial type cable.

MECHANICAL SPECIFICATIONS

Operating Temperature	-30°C to + 70°C
Storage Temperature	-40°C to + 75°C
Crush Resistance	44 N/mm
Tensile Strength	1000N
Nominal Diameter	9mm max
Bend Radius	20 x OD
Cable Weight	90kg/km (approx)

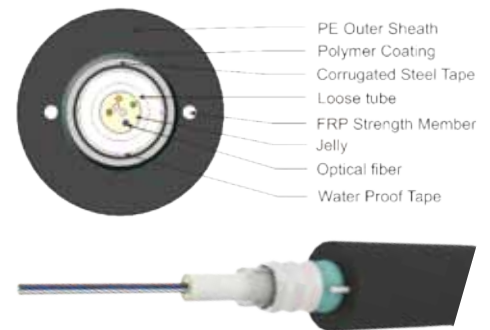

PRODUCT FEATURES

- It can be used in underground conduit, direct buried or aerial applications
- The cable is designed for easy mid-span entry
- The fibers are separated into binder groups inside a central tube gel-filled with water blocking compound
- The steel armor provides rodent and lightning protection
- The sheath jacket material is high density polyethylene for maximum environmental protection and is petrochemical stable
- Qualifies as per EIA/TIA 568B, ISO/IEC 11801

NUMBER	DESCRIPTION
DFXA062GCT04	Unitube, Light-Armoured Cable, Multi-Mode, 4 Core, 62.5µm
DFXA062GCT06	Unitube, Light-Armoured Cable, Multi-Mode, 6 Core, 62.5µm
DFXA062GCT08	Unitube, Light-Armoured Cable, Multi-Mode, 8 Core, 62.5µm
DFXA062GCT12	Unitube, Light-Armoured Cable, Multi-Mode, 12 Core, 62.5µm
DFXA050GCT04	Unitube, Light-Armoured Cable, Multi-Mode, 4 Core, 50µm
DFXA050GCT06	Unitube, Light-Armoured Cable, Multi-Mode, 6 Core, 50µm
DFXA050GCT08	Unitube, Light-Armoured Cable, Multi-Mode, 8 Core, 50µm
DFXA050GCT12	Unitube, Light-Armoured Cable, Multi-Mode, 12 Core, 50µm
DFXA051GCT04	Unitube, Light-Armoured Cable, Multi-Mode, 4 Core, OM3 50µm
DFXA051GCT06	Unitube, Light-Armoured Cable, Multi-Mode, 6 Core, OM3 50µm
DFXA051GCT08	Unitube, Light-Armoured Cable, Multi-Mode, 8 Core, OM3 50µm
DFXA051GCT12	Unitube, Light-Armoured Cable, Multi-Mode, 12 Core, OM3 50µm
DFXA009GCT04	Unitube, Light-Armoured Cable, Single-Mode, 4 Core, 9µm
DFXA009GCT06	Unitube, Light-Armoured Cable, Single-Mode, 6 Core, 9µm
DFXA009GCT08	Unitube, Light-Armoured Cable, Single-Mode, 8 Core, 9µm
DFXA009GCT12	Unitube, Light-Armoured Cable, Single-Mode, 12 Core, 9µm

In/Outdoor Non-Armoured Cables

Digilink In/Outdoor non-armoured cable is constructed with industry standard 2 mm gel-filled, buffer tubes, standard around a central strength member. There is tough UV stabilized HDPE jacket over which there is a special anti termite nylon-12 jacket suitable for duct-pulling.

MECHANICAL SPECIFICATIONS

Operating Temperature	-30°C to 70°C
Storage Temperature	-40°C to 75°C
Crush Resistance	44 N/mm
Tensile Strength	2670N (Installation)
Nominal Diameter	12mm
Bend Radius	20 x OD
Cable Sheath Thickness	2mm
Weight	90kg/km (approx)

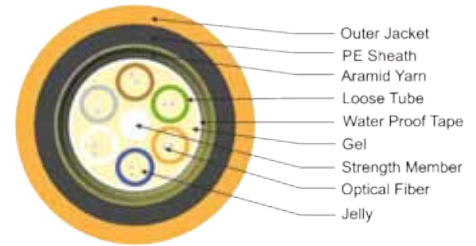

PRODUCT FEATURES

- Constructed with industry standard 2 mm gel-filled, buffer tubes, standard around a central strength member
- The buffer tubes are compatible with standard hardware, cable routing and fan-out kits
- The cable core is water blocked with materials, hydrophobic thixotropic jelly
- 0.6mm thick orange coloured outer jacket of nylon-12 material making in cable anti termite and best suites for duct-pulling with low frictional coefficient
- Qualifies as per EIA/TIA 568B, ISO/IEC 11801

NUMBER	DESCRIPTION
DFXAI62GLH04	In/Outdoor Non-Armoured Cable, Multi-Mode, 4 Core, 62.5µm, LSZH
DFXAI62GLH06	In/Outdoor Non-Armoured Cable, Multi-Mode, 6 Core, 62.5µm, LSZH
DFXAI62GLH12	In/Outdoor Non-Armoured Cable, Multi-Mode, 12 Core, 62.5µm, LSZH
DFXAI62GLH24	In/Outdoor Non-Armoured Cable, Multi-Mode, 24 Core, 62.5µm, LSZH
DFXAI50GLH04	In/Outdoor Non-Armoured Cable, Multi-Mode, 4 Core, 50µm, LSZH
DFXAI50GLH06	In/Outdoor Non-Armoured Cable, Multi-Mode, 6 Core, 50µm, LSZH
DFXAI50GLH12	In/Outdoor Non-Armoured Cable, Multi-Mode, 12 Core, 50µm, LSZH
DFXAI51GLH04	In/Outdoor Non-Armoured Cable, Multi-Mode, 4 Core, OM3 50µm, LSZH
DFXAI51GLH06	In/Outdoor Non-Armoured Cable, Multi-Mode, 6 Core, OM3 50µm, LSZH
DFXAI51GLH12	In/Outdoor Non-Armoured Cable, Multi-Mode, 12 Core, OM3 50µm, LSZH
DFXAI51GLH24	In/Outdoor Non-Armoured Cable, Multi-Mode, 24 Core, OM3 50µm, LSZH
DFXAI09GLH04	In/Outdoor Non-Armoured Cable, Single-Mode, 4 Core, 9µm, LSZH
DFXAI09GLH06	In/Outdoor Non-Armoured Cable, Single-Mode, 6 Core, 9µm, LSZH
DFXAI09GLH12	In/Outdoor Non-Armoured Cable, Single-Mode, 12 Core, 9µm, LSZH
DFXAI09GLH24	In/Outdoor Non-Armoured Cable, Single-Mode, 24 Core, 9µm, LSZH

Tight Buffer Building Cables

Digilink tight buffer building cable is constructed for indoor application with tight buffer tubes on each fiber. This cable construction make the cable suitable for fiber to desktop application. Fibers are strengthened by extruding plastic upto 900µm around them. Aramid yarn is used to provide tensile strength. Fire retardant orange PVC jacket protects the cable from mechanical stress.

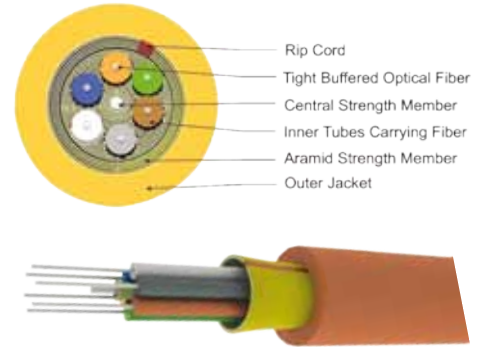

MECHANICAL SPECIFICATIONS

Operating Temperature	-30°C to + 70°C
Storage Temperature	-40°C to + 75°C
Crush Resistance	22 N/mm
Tensile Strength	400N
Bend Radius	20 x OD

PRODUCT FEATURES

- 900 micron tight buffered construction allows for direct termination eliminating the need for furcation which minimizes installation expense
- This cable utilizes water blocking technology which makes the cable suitable for the indoor and outdoor environment, with gel-free cable access
- Meets requirement for tight buffered construction and suitable for installation in true OSP environmental conditions
- Also available in tactical jacket
- Qualifies as per EIA/TIA 568 B, ISO/IEC 11801

NUMBER	DESCRIPTION
DFXAI62PDG04	Tight Buffer Building Cable, Multi-Mode, 4 Core, 62.5µm
DFXAI62PDG06	Tight Buffer Building Cable, Multi-Mode, 6 Core, 62.5µm
DFXAI62PDG12	Tight Buffer Building Cable, Multi-Mode, 12 Core, 62.5µm
DFXAI50PDG04	Tight Buffer Building Cable, Multi-Mode, 4 Core, 50µm
DFXAI50PDG06	Tight Buffer Building Cable, Multi-Mode, 6 Core, 50µm
DFXAI50PDG12	Tight Buffer Building Cable, Multi-Mode, 12 Core, 50µm
DFXAI51PDG04	Tight Buffer Building Cable, Multi-Mode, 4 Core, OM3 50µm
DFXAI51PDG06	Tight Buffer Building Cable, Multi-Mode, 6 Core, OM3 50µm
DFXAI09PDG04	Tight Buffer Building Cable, Single-Mode, 4 Core, 9µm
DFXAI09PDG06	Tight Buffer Building Cable, Single-Mode, 6 Core, 9µm
DFXAI09PDG12	Tight Buffer Building Cable, Single-Mode, 12 Core, 9µm

Wall Mount Fiber Enclosure

Digilink wall mount fiber enclosure is essentially a fiber distribution box wherein the fiber backbone cables and the equipment cables are terminated. The fiber spools provide minimum bending radius and the splice trays function as a splice cover for pigtail splicing.

MECHANICAL SPECIFICATIONS

Material	Box-powder coated aluminum alloy
Spool	FR grade ABS
Cable Grommets	FR grade nylon
Splice Tray	Aluminum + ABS
Splice Tray Dimensions	140 x 125 x 10mm
Dimensions	370 x 350 x 80 (H*W*D)



PRODUCT FEATURES

- Two compartment design-one side cable, another side pigtails/patch cords
- Aluminium housing with durable epoxy powder coating
- Lock and key ensuring safety, avoiding unauthorised tempering
- Allows minimum two cable entries

NUMBER	DESCRIPTION
DFXOX06WXXX	1U, 6-Port, Wall Mount, Fiber Enclosure
DFXOX12WXXX	1U, 12-Port, Wall Mount, Fiber Enclosure
DFXOX24WXXX	1U, 24-Port, Wall Mount, Fiber Enclosure

Rack Mount Fiber Patch Panel

Digilink rack mount fiber patch panel is essentially a fiber distribution box wherein the fiber backbone cables and the equipment cables are terminated. The fiber spools provide minimum bending radius and the splice trays function as a splice cover for pigtail splicing.



MECHANICAL SPECIFICATIONS

Material	Box-powder coated aluminum alloy
Spool	FR grade ABS
Cable Grommets	FR grade nylon
Splice Tray	Aluminum + ABS
Splice Tray Dimensions	140 x 125 x 10mm
Dimensions	370 x 350 x 80 (H*W*D)

PRODUCT FEATURES

- Aluminium housing with durable epoxy powder coating
- Suitable for 19" rack mountable cabinet
- Allow minimum two cable entries
- Flame retardant plastic, high impact resistance cable spool
- Qualifies as per ISO/IEC 11801
- EN 20173

NUMBER	DESCRIPTION
DFXOX06RXXX	1U, 6-Port, Rack Mount, Fiber Patch Panel
DFXOX12RXXX	1U, 12-Port, Rack Mount, Fiber Patch Panel
DFXOX24RXXX	1U, 24-Port, Rack Mount, Fiber Patch Panel
DFXNLSCX03	1U, SC Duplex, Fiber Patch Plate, with 3 Adaptors
DFXNLLC06X	1U, LC Duplex, Fiber Patch Plate, with 6 Adaptors
DFXNLST06X	1U, ST Duplex, Fiber Patch Plate, with 6 Adaptors
DFXNLBLANK	1U, 6-Port, Fiber Blank Connector Plate

Connectors

Digilink connectors are available in both Single Mode and Multi Mode fiber with excellent diameter tolerance, these connectors can be used with recommended anarobic adhesive or heat curis epoxy. They are available in all varities larger form factor 2.5mm ferules type ST, SC, FC to recent small form factor connectors like LC, MTRJ

MECHANICAL SPECIFICATIONS

Insertion Loss	< 0.3 dB (For sm)
-	< 0.53 dB (For mm)
Durability (500 Mappings)	< 0.2 dB Max
Compatible Optical Fiber	9/125 μm, 50/125 μm, 62.5/125 μm
Operating Temperature	-20°C to 80°C



PRODUCT FEATURES

- Keeping in view the size of fiber and accuracy in alignment the connectors use precisely machine ceramic ferrules
- Fully in compliant with JIS C5973 F04 Type
- Connectors comply to EIA/TIA 568 B as well as ISO/IEC 11081 standards
- For 3.0 mm cable & 0.9 mm tight buffered fiber
- Connectors are UL listed as well as RoHS complied
- Multimode version are suitable for both 62.5/125 and 50/125 μm fiber

NUMBER	DESCRIPTION
DFXOSTXSPR09	ST Connector, Single-Mode, 0.9mm
DFXOSCXSPR09	SC Connector, Single-Mode, 0.9mm
DFXOFCXSPR30	FC Connector, Single-Mode, 3.0mm
DFXOMTJSPR09	MTRJ Connector, Single-Mode, 0.9mm
DFXOLCXSPR20	LC Connector, Single-Mode, 2.0mm
DFXOSTXMPR09	ST Connector, Multi-Mode, 0.9mm
DFXOSCXMPR09	SC Connector, Multi-Mode, 0.9mm
DFXOMTJMPR20	MTRJ Connector, Multi-Mode, 2.0mm
DFXOLCXMPR20	LC Connector, Multi-Mode, 2.0mm

Adaptors

Digilink offers broad range of fiber adapters for different type of connectors. These adapters are available in both Single Mode and Multi Mode version also in choice of Simplex and Duplex type.

MECHANICAL SPECIFICATIONS

Insertion Loss	< 0.3 dB max
Durability (1000 Matings)	< 0.2 dB max
Compatible Optical Fiber	9/125 μm, 50/125 μm, 62.5/125 μm
Material Ferrule	Phosphor bronze (for MM), Zirconia (for SM)
Operating Temperature	-40°C to 80°C

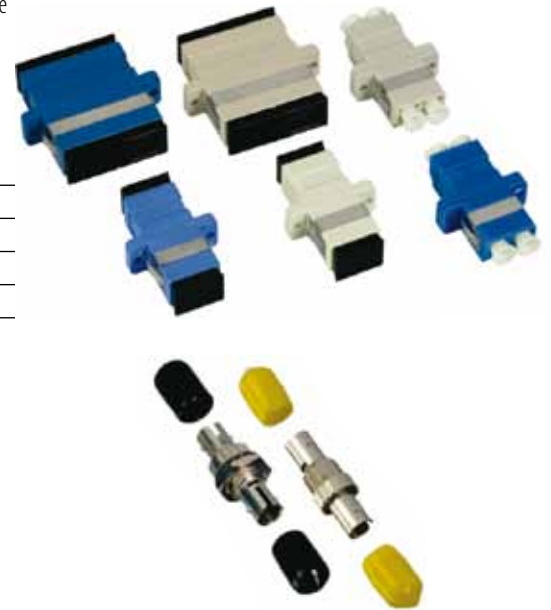

PRODUCT FEATURES

- Zirconia or Phosphor Bronze Sleeve
- Compliant as per EIA/TIA 568-C.0
- Compliant as per ISO/IEC 11081
- UL Listed
- RoHS Compliant
- IEC-874

NUMBER	DESCRIPTION
DFXDSTTYPXZS	ST Adaptor, Simplex, Single-Mode, Zirconia Sleeve
DFXDFCTYPSQZS	FC Adaptor, Simplex, Single-Mode, Zirconia Sleeve
DFXDSTYYPXZS	SC Adaptor, Simplex, Single-Mode, Zirconia Sleeve
DFXDSTYYPDZS	SC Adaptor, Duplex, Single-Mode, Zirconia Sleeve
DFXDLCTYYPDZS	LC Adaptor, Duplex, Single-Mode, Zirconia Sleeve
DFXDLCTYYPDPM	LC Adaptor, Duplex, Multi-Mode, Phosphor Bronze Sleeve
DFXDSTYYPXPM	SC Adaptor, Simplex, Multi-Mode, Phosphor Bronze Sleeve
DFXDSTYYPDPM	SC Adaptor, Duplex, Multi-Mode, Phosphor Bronze Sleeve
DFXDSTTYPXPM	ST Adaptor, Simplex, Multi-Mode, Phosphor Bronze Sleeve

Fiber Patch Cords and Pigtails

Digilink fiber patch cords are offered in riser rated UL listed options. Using the fiber patch cord product identifier, fiber patch cord can be ordered with custom configured length cordage size, jacket type and length, providing the ultimate in flexibility to meet any cabling infrastructure.

MECHANICAL SPECIFICATIONS

Outside Diameter (Simplex)	1.6mm x 3.0mm
Outside Diameter (Duplex)	1.6mm x 3.0mm
Minimum Cable Retention Strength	1.6mm: 11.24 lbs (50 N)



PRODUCT FEATURES

- SM Support for a wide variety of applications, including CWDM 60% increase in usable bandwidth with zero water peak singlemode
- Available 1.6 mm cordage making these the smallest cords in the industry
- Pull proof connector designs prevent unintended disconnect
- Distinctive colour-coding for colorary Identification

NUMBER	DESCRIPTION
DFXCD3SCSC01	SC-SC 62.5µm Duplex, Multi-Mode, Patch Cord 1m
DFXCD3LCSC01	LC-SC 62.5µm Duplex, Multi-Mode, Patch Cord 1m
DFXCD3LCLC01	LC-LC 62.5µm Duplex, Multi-Mode, Patch Cord 1m
DFXCD3SCSC02	SC-SC 62.5µm Duplex, Multi-Mode, Patch Cord 2m
DFXCD3LCSC02	LC-SC 62.5µm Duplex, Multi-Mode, Patch Cord 2m
DFXCD3LCLC02	LC-LC 62.5µm Duplex, Multi-Mode, Patch Cord 2m
DFXCD3SCSC03	SC-SC 62.5µm Duplex, Multi-Mode, Patch Cord 3m
DFXCD3LCSC03	LC-SC 62.5µm Duplex, Multi-Mode, Patch Cord 3m
DFXCD3LCLC03	LC-LC 62.5µm Duplex, Multi-Mode, Patch Cord 3m
DFXGS3LCXX01	LC, 62.5µm Simplex, Multi-Mode, Pigtail 1m
DFXGS3SCXX01	SC, 62.5µm Simplex, Multi-Mode, Pigtail 1m
DFXGS3LCXX02	LC, 62.5µm Simplex, Multi-Mode, Pigtail 2m
DFXGS3SCXX02	SC, 62.5µm Simplex, Multi-Mode, Pigtail 2m
DFXGS3LCXX03	LC, 62.5µm Simplex, Multi-Mode, Pigtail 3m
DFXGS3SCXX03	SC, 62.5µm Simplex, Multi-Mode, Pigtail 3m

Fiber Patch Cords and Pigtails

NUMBER	DESCRIPTION
DFXCD2SCSC01	SC-SC 50µm Duplex, Multi-Mode, Patch Cord 1m
DFXCD2LCSC01	LC-SC 50µm Duplex, Multi-Mode, Patch Cord 1m
DFXCD2LCLC01	LC-LC 50µm Duplex, Multi-Mode, Patch Cord 1m
DFXCD2SCSC02	SC-SC 50µm Duplex, Multi-Mode, Patch Cord 2m
DFXCD2LCSC02	LC-SC 50µm Duplex, Multi-Mode, Patch Cord 2m
DFXCD2LCLC02	LC-LC 50µm Duplex, Multi-Mode, Patch Cord 2m
DFXCD2SCSC03	SC-SC 50µm Duplex, Multi-Mode, Patch Cord 3m
DFXCD2LCSC03	LC-SC 50µm Duplex, Multi-Mode, Patch Cord 3m
DFXCD2LCLC03	LC-LC 50µm Duplex, Multi-Mode, Patch Cord 3m
DFXGS2LCXX01	LC, 50µm Simplex, Multi-Mode, Pigtail 1m
DFXGS2SCXX01	SC, 50µm Simplex, Multi-Mode, Pigtail 1m
DFXGS2LCXX02	LC, 50µm Simplex, Multi-Mode, Pigtail 2m
DFXGS2SCXX02	SC, 50µm Simplex, Multi-Mode, Pigtail 2m
DFXGS2LCXX03	LC, 50µm Simplex, Multi-Mode, Pigtail 3m
DFXGS2SCXX03	SC, 50µm Simplex, Multi-Mode, Pigtail 3m
DFXCD4SCSC01	SC-SC OM3 Duplex, Multi-Mode, Patch Cord 1m
DFXCD4LCSC01	LC-SC OM3 Duplex, Multi-Mode, Patch Cord 1m
DFXCD4LCLC01	LC-LC OM3 Duplex, Multi-Mode, Patch Cord 1m
DFXCD4SCSC02	SC-SC OM3 Duplex, Multi-Mode, Patch Cord 2m
DFXCD4LCSC02	LC-SC OM3 Duplex, Multi-Mode, Patch Cord 2m
DFXCD4LCLC02	LC-LC OM3 Duplex, Multi-Mode, Patch Cord 2m
DFXCD4SCSC03	SC-SC OM3 Duplex, Multi-Mode, Patch Cord 3m
DFXCD4LCSC03	LC-SC OM3 Duplex, Multi-Mode, Patch Cord 3m
DFXCD4LCLC03	LC-LC OM3 Duplex, Multi-Mode, Patch Cord 3m
DFXGS4LCXX01	LC, OM3 Simplex, Multi-Mode, Pigtail 1m
DFXGS4SCXX01	SC, OM3 Simplex, Multi-Mode, Pigtail 1m
DFXGS4LCXX02	LC, OM3 Simplex, Multi-Mode, Pigtail 2m
DFXGS4SCXX02	SC, OM3 Simplex, Multi-Mode, Pigtail 2m
DFXGS4LCXX03	LC, OM3 Simplex, Multi-Mode, Pigtail 3m
DFXGS4SCXX03	SC, OM3 Simplex, Multi-Mode, Pigtail 3m
DFXCD1SCSC01	SC-SC Duplex, Single-Mode, Patch Cord 1m
DFXCD1LCSC01	LC-SC Duplex, Single-Mode, Patch Cord 1m
DFXCD1LCLC01	LC-LC Duplex, Single-Mode, Patch Cord 1m
DFXCD1SCSC02	SC-SC Duplex, Single-Mode, Patch Cord 2m
DFXCD1LCSC02	LC-SC Duplex, Single-Mode, Patch Cord 2m
DFXCD1LCLC02	LC-LC Duplex, Single-Mode, Patch Cord 2m
DFXCD1SCSC03	SC-SC Duplex, Single-Mode, Patch Cord 3m
DFXCD1LCSC03	LC-SC Duplex, Single-Mode, Patch Cord 3m
DFXCD1LCLC03	LC-LC Duplex, Single-Mode, Patch Cord 3m
DFXGS1SCXX01	SC, Simplex, Single-Mode, Pigtail 1m
DFXGS1STXX01	ST, Simplex, Single-Mode, Pigtail 1m
DFXGS1LCXX01	LC, Simplex, Single-Mode, Pigtail 1m
DFXGS1SCXX02	SC, Simplex, Single-Mode, Pigtail 2m
DFXGS1STXX02	ST, Simplex, Single-Mode, Pigtail 2m
DFXGS1LCXX02	LC, Simplex, Single-Mode, Pigtail 2m
DFXGS1SCXX03	SC, Simplex, Single-Mode, Pigtail 3m
DFXGS1STXX03	ST, Simplex, Single-Mode, Pigtail 3m
DFXGS1LCXX03	LC, Simplex, Single-Mode, Pigtail 3m

Technical Information

General Installation Tips

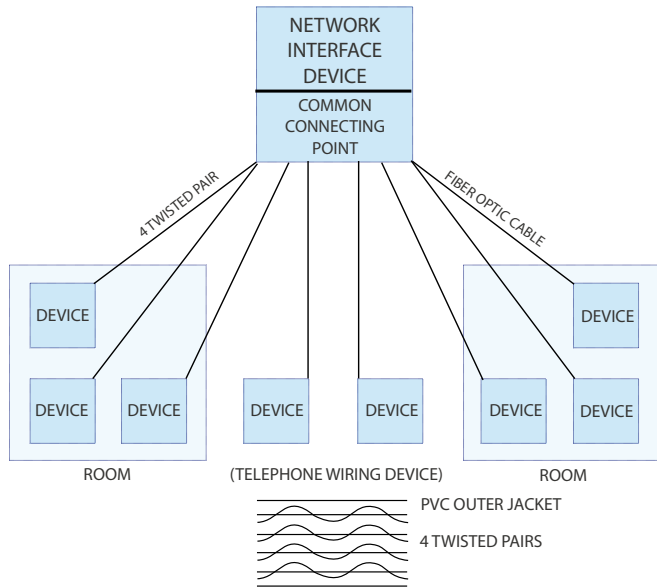

Horizontal Wiring (Pathways)
From the Telecommunications closet to the individual workstations

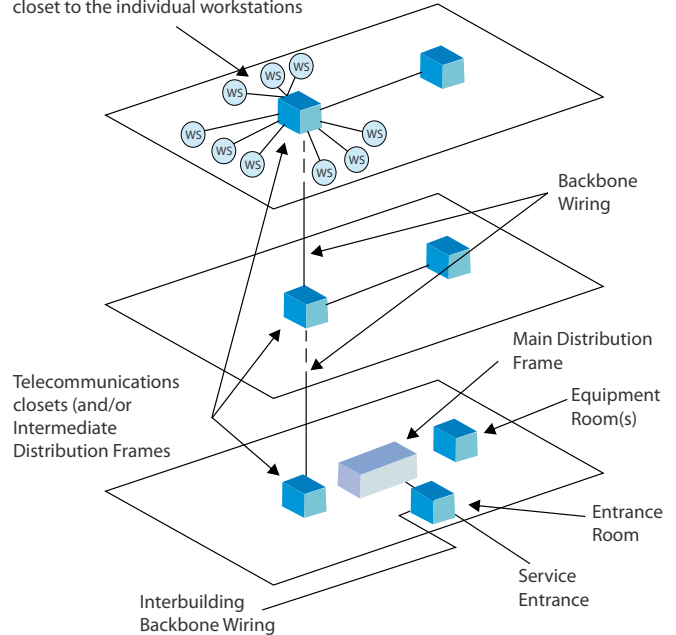

TIA Preferred Wiring Method

The wiring method preferred by the Telecommunication Industry Association (TIA) is a star wiring method (see fig below). Each individual workstation in a residential or commercial building is wired directly to the distribution device with four-pair twisted wire or fiber optic cable.

Star Topology

The star topology uses a hierarchical series of distribution frames. The backbone includes the main distribution frame (MDF) and the optional intermediate distribution frame (IDF). The first level, the MDF, links to other levels via the backbone cabling. The MDF may link to the third and final level, the telecommunications closet (TC) directly, or in large installations it may link to some TCs via an optional second level, the intermediate distribution frame (IDF). The TC terminates the backbone cable and cross-connects to the horizontal cabling. The horizontal cabling terminates in the work area at the workstation (WS).

General

Horizontal cabling is the cabling from the telecommunications closet to the work-area. It includes the cross-connects in the telecommunications closet; horizontal cabling; and the outlet at the work areas. Commercial building horizontal cabling should be installed such that it will:

- (a) Facilitate ongoing maintenance, relocations, and additions
- (b) Accommodate future equipment and service changes
- (c) Accommodate a diversity of user applications, including voice, data, LAN, switching, and other building services

Roughing In Correctly

The following are general rules for running cable, whether residential, or commercial:

- **Always make a quick check for shorts, opens, and ground when the rough-in is completed.** Lightweight telephone wiring is much easier to damage than non-metallic cable. The jacket can be caught on sharp edges or nail points and inside

conductors grounded, shorted, or broken. It will take just a few minutes to insure that no connections or splicing were forgotten and that no wiring was damaged as it was pulled in or secured during rough-in

- **Do not splice wires on the cable runs.** Pull a new wire if things go wrong
- **Do not exert more than 25 pounds (110N) of pulling tension on 4-pair cables.** Larger capacity cables should be pulled as per the manufacturers directions
- **Do not run cables in parallel with power wiring.** Consult industry standards for minimum separation of telecommunications cable from interference sources
- **Do not bend cable sharply or nick the protective sheath covering the insulated wires**
- **Maintain polarity.** (i.e., carefully match wire colors) of the Tip (+) and Ring (-) pairs from the demarcation point to the outlets. Polarity reversal causes problems with some devices
- **Maintain the access line number correlation with the pair number.** (i.e., access line once goes to pair one, and so forth) when wiring connectors
- **Use the two inner pairs of housing for telecommunications.** Use the outer pairs of the connector for other purposes (if any) to provide compatibility with two-line telephones
- **Use plastic non-metallic staples** to support wire, and leave the wire loose inside the staples—do not drive staples all the way in. Driving staples in tightly may crimp wire and damage the insulation or wire, impairing its ability to carry voice or data
- **If conduit is installed, always leave a pull cord in to facilitate running new wire**
- **Never run power in the same conduit with telecommunications cable.** Low-voltage monitor and control lines may share conduit with telecommunications
- **Avoid undercarpet runs if possible,** as they are inherently more susceptible to damage, particularly in residences. If they must be installed, follow the manufacturer's directions carefully, and remember that only one transition from one type of cabling to another is standard in a single room. Avoid installing undercarpet runs in damp areas. Note that undercarpet power cables are not allowed in residential installations
- **Where possible, use inner walls for runs to avoid conflict with firebreaks and insulation.** Inner-wall wiring also makes it a lot easier to replace wires if

General Installation Tips

necessary, or to add wires. Nonetheless, wiring through external walls is not always avoidable, so installation handling should always be the same as for electrical wire. Firestopping is also to be observed

- **Do not run telecommunications wire parallel to power wiring without adequate separation, and do not share bore holes with power wires**
- **Keep wire away from source of heat**, like hot water pipes and heater ducts
- **Avoid running external wires** they are not desirable, both for appearance and safety reasons. Wires on the outside of the building may be allowed under local code for additions, but should be avoided for initial installations
- **Leave 18 inches of spare wire at outlets and connection points** for connections and changes
- **Firestopping, bonding, and grounding must be performed according to fire, building, and electrical codes that apply** Regardless of the installation type, proper wiring requires good planning and careful work to avoid damaging cables and to make good connections

Telecommunications Outlets

- When installing outlet boxes on wooden studs, it is important to maintain proper separation of communications and power cables. These two types of cables should not share drill holes or stud spaces. Desk telephone connectors should be located at the same distance from the floor as electrical outlets
- Each workstation should, at minimum, be served by either two 100 ohms UTP cables, or one 100 ohm UTP cable and one cable of another type. Single or double outlets may be used
- Telecommunications outlets are usually placed at the same height as electrical outlets, and near an electrical outlet

The Importance of Pair Twisting

The rate of twisting will range from 4 to as many as 28 twists per foot(0.3m) on high speed data cable. The tighter the twist, the less likely it will be distorted during installation, and the greater the immunity from interference. While the specification for the rate of twist varies with the anticipated data rate carried by the installation, always untwist the least amount of cable necessary to make a connection

- Category 5e max. allowed untwisting = $< \frac{1}{2}$ " (13mm)
- Category 6 max. allowed untwisting = $< \frac{1}{2}$ " (13mm)

General Tips on Quality Installations

- Every connection degrades system performance, so use the minimum necessary
- Better to provide excess capacity in terms of cable and outlets rather than not enough. Later additions are costly and time consuming
- Wire to the highest anticipated data rate (speed) or greater-never less
- Never install components of unknown/questionable origin or quality. At the very best, the system will transmit signals to the level of its weakest component. Every element and connection is important
- Document all connections carefully, and keep installations neat and tidy. This will save time and hassle when modifying or troubleshooting the system later
- Test everything

Connector Termination

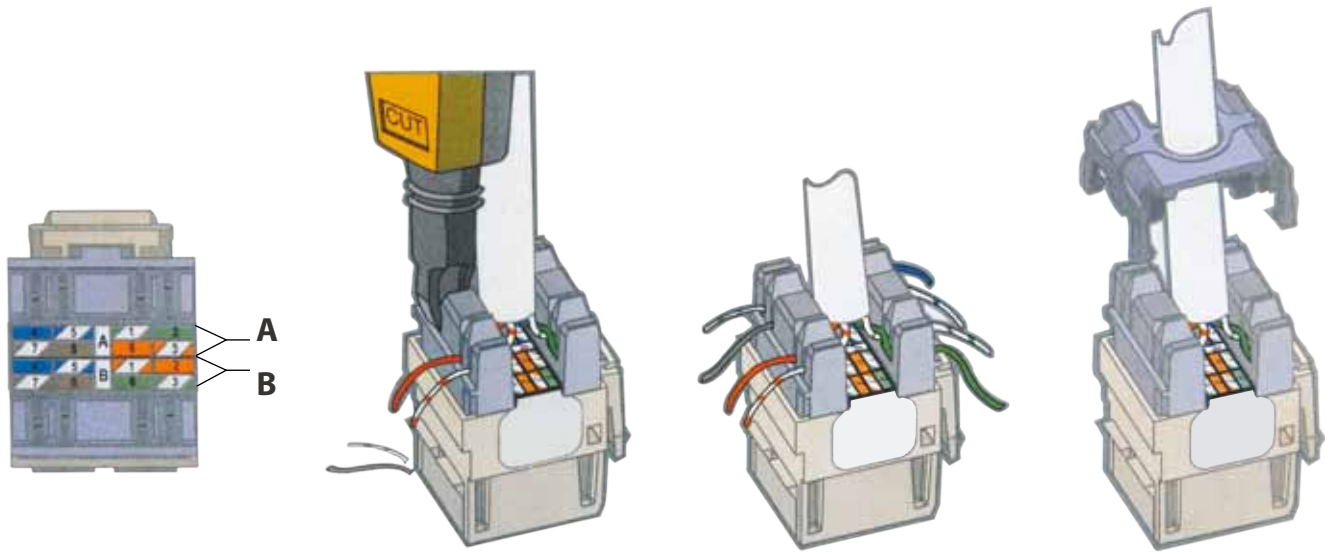

Description

- Remove about 3”(76mm) of cable jacket and center spline (stiff wire separator inside cable)
- Determine which wiring scheme to use, T568A or T568B. Note the associated color codes and connector pin numbers on the label located between the IDC connector slots
- Leave the cable jacket within 1/8”(3mm) of the connector side, then route the wires for termination using the selected wiring scheme. Note: Route cable perpendicular to the IDC field. Ensure there is enough slack in the twisted pairs, and do not place the cable jacket into the termination field
- Use your fingers to carefully seat the wires into the IDC slots. Set a 11 O-style impact tool to low impact and position it perpendicular to the connector. Maintain wire pair twisting to within less than 1/2”(13mm) of the IDC contact; then, seat and trim the cable one pair at a time to prevent crushing the inside pairs
- Place the dust cap over the terminated wires for secure connection

Inside Wire Colours: Wiring Standard

Pin#	T568A	T568B
1	White/Green	White/Orange
2	Green	Orange
3	White/Orange	White/Green
4	Blue	Blue
5	White/Blue	White/Blue
6	Orange	Green
7	White/Brown	White/Brown
8	Brown	Brown

Note: For some cables, wires for jack pin numbers 2, 4, 6 and 8 may have a white stripe. This is equivalent to cables with solid wires for the same.

Standards Overview

Computer Network Cabling Standards

Engineering Standards and publication are designed to serve the general public through eliminating misunderstandings between manufacturers and purchasers, facilitating interchangeability and improvements of products and assisting the purchaser in selecting and obtaining with minimum delay the proper product for his particular need.

The standards are constantly evolving. The cabling standards are also no exception to it. In recent years there have been so many rapid developments in cabling technologies that the quality of today's cabling and connecting hardware far exceeds the best products available a few years ago. While the standards and technologies have evolved, the user is yet to be fully aware of all the developments that are taking place and this has left him bewildered. In the fear of obsolescence, he goes in for so called 'the latest' and ends up paying a high price for the performance which he either does not need or his network is incapable of delivering.

The standards organizations do not ease the matters either. Very regular the standards are revised, updated or rescinded. Various companies in order to be ahead of the competition, lay their quick claims on the release of the products which meet these latest revisions, either rightly or not. This scramble for the top slot keeps the market place in a state of confusion, and the end user in a helpless position. Thus a standards, instead of eliminating the misunderstanding, breeds it. This defeats the basic purpose of the standards.

Hence there is a need for removal of this misconception and educate the customer on various aspects of standards, the standards organizations, their scope, relevance to the applications, network requirements, desired performance and most important, the budget. The applicable standards are to be chosen after careful study and proper understanding of the subject.

This document describes the various prevalent standards, the parameters to be measured, standards organizations and its importance to the user.

The organizations and their standards

There are several organizations that influence the data cabling standards such as

Organizations	Standards	
ANSI/TIA	568 C	Commercial Building Telecommunication standard
CENLEC	EN 50173	Customer Premises Cabling for IT
ISO/IEC	IS 11801	Generic cabling for customer premises
IEEE	IEEE	LAN/WAN/MAN standards
ATM	-	Data communication protocol

Cabling Measurements

There are various measurements to be carried out on the cabling to ascertain its conformance to the specifications and standards. This is in addition to the testing, which assures functionality and helps locating the faults. The various measurements to be carried out are:

- a. Wiremap And Length
- b. Delay And Delay Skew
- c. Near End Crosstalk (next)
- d. Power Sum Next
- e. Fext And Elfext
- f. Attenuation
- g. Attentions To Crosstalk Ratio
- h. Impedance
- i. Structural Return Loss
- j. Dc Loop Resistance

Before we look at the actual measurements to be carried out, it will be worthwhile to understand the basic definitions of the above terms:

a. Wiremap and Length

Wiremap checks for point-to-point continuity of the installation. It is the most important parameter since many properties depend on the pin configuration of the channel. Wiremap identifies the location of opens, breaks and pairs that are shorted. The various wiremap failures could be because of shorted pairs, split pairs and transposed pairs. The measurement of length is important in a channel because of the pairs twists incorporated in cables. Hence a channel of 100m (max length), on measurement will be a little over the mark. The measurement takes into account the time required for the signal to traverse the entire length and the MVP (Nominal velocity of propagation) of the cable.

b. Delay

Delay is a measure of time required for a signal to propagate from one end of the circuit to the other. It is usually measured in Nanoseconds. The worst-case Delay should not exceed 1 microsecond for a 100-meter length.

Delay skew

Delay skew is the difference between the propagation delay on the fastest and slowest pairs in a UTP cable. Delay skew is important because the high-speed network usually rely on all four pairs for transmission of information. If receiving end at different times thus making it impossible to reconstruct the original signal. The worst case skew shall be less than 50 nanoseconds for a 100-meter length

c. Near End Crosstalk (NEXT)

The cross talk occurs when an adjacent pair of wires picks up a strong signal on one pair of wires. NEXT is that portion of the transmitted signal that is electromagnetically coupled back into the received signal. The receiver may not be able to distinguish between the real received signal and the crosstalk noise.

Low crosstalk (desired) is a high number which means difference between the magnitude of the transmitted signal and its associated crosstalk is very high it is necessary to measure NEXT at both ends of the cable as the results could be found to be greatly varying.

d. Power Sum NEXT

The power sum NEXT is derived from the algebraic summation of the individual NEXT effects on each pair by the other three pairs PSNEXT is an important measurement where in the cables support high speed 4 pair transmission.

e. Far End Crosstalk (FEXT)

Far End crosstalk is similar to NEXT, except that the signal is sent from the local end, and the crosstalk is measured at the far end. FEXT has to be measured at both the ends.

Equal Level Far End Crosstalk (ELFEXT)

FEXT is highly influenced by the length of the cable since the signal strength inducing the crosstalk is affected by how much it has been attenuated from its source. Hence ELFEXT is preferred ELFEXT subtracts attenuation from the result so that the result is normalized for attenuation effects.

f. Attenuation

The loss of signal level with distance is called attenuation loss. Since it is a loss it is usually expressed as a negative value.

Standards Overview

g. Attenuation to Crosstalk Ratio (ACR)

Due to attenuation the signal are their weakest at the receiving end of the link. The attenuation determines the strength of the received signal while the noise is from the station's own transmitter attenuation to crosstalk Rations (ACR) is the difference between the crosstalk loss and the attenuation for the pair in the link being tested. Thus, grater the ACR, better it is.

h. Impedance

Impedance is a measure in ohms and includes the effects of resistance, inductance and capacitance. UTP is generally rated at 100 ohms and it remains constant over the expected frequency range. Various components in a channel should have impedance ratings. This is to ensure complete data transfer (Impedance matching).

i. Structural Return Loss

It is a measure of uniformity of the cable's impedance. As the cables are not perfectly uniform in construction these variances cause impedance changes in the cable. Each impedance change contributes to loss in signal strength. Return Loss of a link is a measure of the overall uniformity of link's impedance, relative to a nominal value, usually 100 Ohms in case of UTP.

j. DC Loop Resistance

DC loop resistance is a measure of the linear DC loss of a conductor, which is about 9.4 Ohms per 100m.

Brief Overview of EIA/TIA 568 B: The TIA 568 B is the latest update from EIA/TIA of commercial building telecommunication standard. It replaces TIA 568 A and the associated TSB and the addendum. Significant additions include Category 5e/6 performance levels, 50/125 mm fiber and allowance for alternate connectors other than the SC. Category 5 is no more recognized in horizontal cabling. It is divide in three parts:

- B1 Link/Channel requirements.
- B2 Copper component and cable requirement.
- B3 Fiber requirement.

Our structured cabling products strictly adhere to the standards formulated by ANS/EIA/TIA 568 A/B. The latest editions of the EIA/TIA 568-A was published in the year 1995. The highlights of AUSI/EIA/TIA 568-A.

The Cabling Elements Specified

- Horizontal Cabling. Telecommunications Closets. Backbone Cabling. Work area
- Equipment rooms. Entrance facilities. Administration.

Scope

This standard specifics minimum requirements for telecommunications cabling within a commercial building, upto and including telecommunications outlet/connector, and between buildings in a campus environment. It also specifics component requirements, cabling distances, telecommunications outlet connectors configurations and a recommended topology. This standard intends to support a wide range of different commercial building sites and applications. This includes sites with upto 1,000,000m² of spaces and with a population of upto 50,000 individual users.

Horizontal Cabling

The horizontal cabling is that portion of the telecommunications cabling system that extends from the horizontal cross connects in the telecommunications closet. The horizontal cabling includes the horizontal cables, the telecommunications outlet/connector in the work area, the mechanical termination and patch cords located in

telecommunication closet. The horizontal cabling contains the greatest quantity of individual cables in the building. It is much less accessible than the backbone cabling. The time, effort, and skills required for changes can be extremely high. Further, access to the horizontal cabling causes disruption to the work. Hence maximum consideration should be given to accommodating a diversity of user applications in order to reduce or eliminate the probability of requiring changes to the horizontal cabling as the user needs evolve.

Fig. 1 - Typical Telecommunication Cabling System

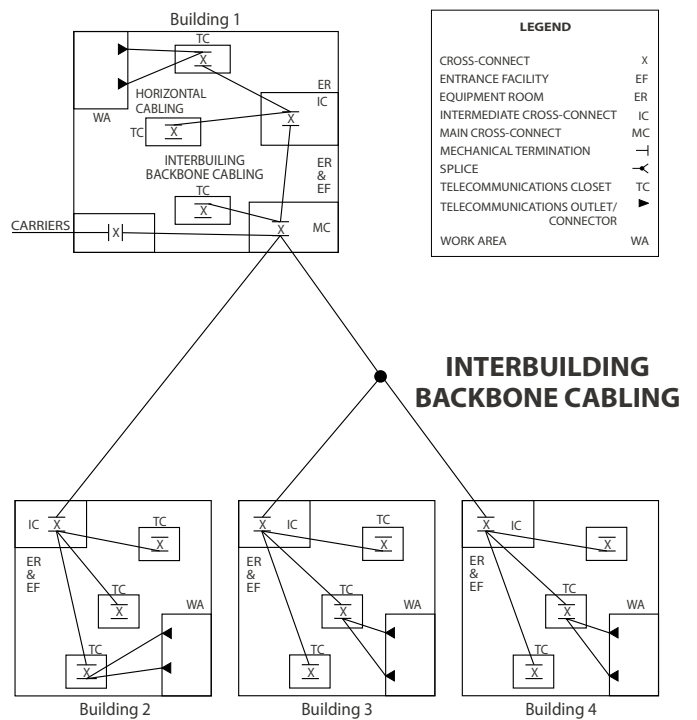
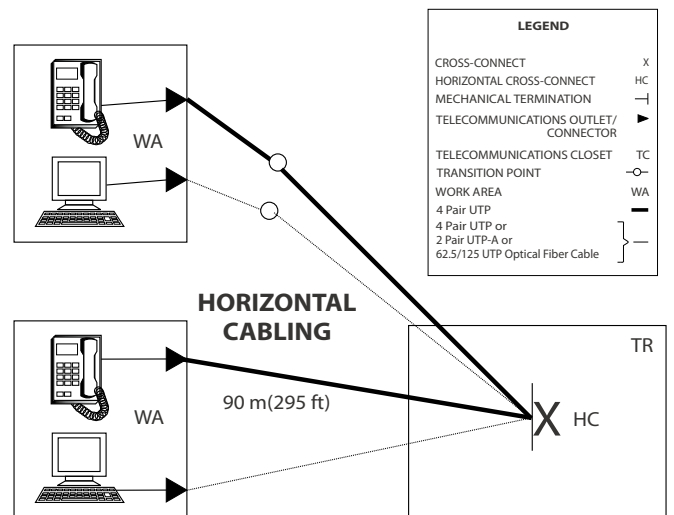

Fig. 2 - Typical Horizontal and Work Area Cabling



Standards Overview

Horizontal distances

The maximum horizontal distance shall be 90 mtrs. Independent of the media type. This is the cable length from the mechanical termination of the media at the horizontal cross connect in the telecommunication closet to the telecommunications outlet in the work area. Length limitations for cross connect jumpers and patch cords in the connect facilities that connect horizontal cabling with equipment or backbone cabling should not exceed 6 mtrs. in length.

Recognized cables in the horizontal cabling subsystem

Three types of cables:

1. 4 pair 100Ohms Unshielded Twisted Pair cables (UTP cables) or Screened Twisted Pair (ScTP)
2. Two or more optical fiber multi mode (62.5/125µm)
3. Hybrid Cables, consisting of more than one of the recognised cables a common sheath, may be used in horizontal cabling

The following guidelines need to be adhered to on complementing horizontal cabling

1. Grounding must conform to applicable building code as well as ANSI/EIA/TIA607.
2. A minimum of two telecommunication outlets for individual work area. Both the outlets may be housed in one or two separate information outlets.
 - First outlet:** 100 Ohms twisted pair Cat 5e and above.
 - Second outlet:** 100 Ohms twisted pair Two fiber multi mode optical fiber either 62.5/125µm or 50/125µm.
3. One transition point is allowed between different forms of the same cable type
4. 50 Ohms Co-ax and 150 Ohms STP-A Cabling is not recommended for new installations
5. Additional outlets may be provided. These outlets are in the minimum specified under the standard.
6. Bridged taps and splices are not allowed for copper based horizontal cabling.
7. Application specific components shall be placed external to the telecommunication outlet or horizontal cross connect.
8. Each work area telecommunication outlet shall be connected to a horizontal cross connect in the telecommunication closet.
9. Each work area should be served by a telecommunication closet located on the same floor.
10. Horizontal cabling shall contain not more than one transition point between flat under carpet cable and one of the equivalent horizontal cables.

LEGEND	
CROSS-CONNECT	X
EQUIPMENT ROOM	ER
HORIZONTAL CROSS-CONNECT	HC
INTERMEDIATE CROSS-CONNECT	IC
MAIN CROSS-CONNECT	MC
MECHANICAL TERMINATION	—
TELECOMMUNICATIONS CLOSET	TC
TELECOMMUNICATIONS OUTLET/CONNECTOR	▶
WORK AREA	WA

Fig. 3 - Backbone Hierarchical Star Topology

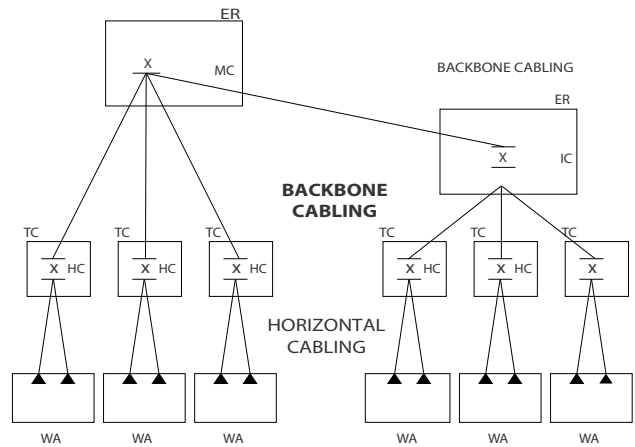

Backbone Cabling

The function of the backbone cabling is to provide interconnections between telecommunication closet equipment rooms and entrance facilities in the telecommunication cabling system. Backbone Cabling consists of the backbone cables, intermediate and main cross-connects, mechanical terminations and patch cords or jumpers used for backbone cross-connection. Backbone Cabling also includes cabling between buildings.

Topology: The Backbone Cabling shall use the conventional hierarchical star topology wherein each horizontal cross-connects in a telecommunication closet is cabled to a main cross-connect or an intermediate cross-connects, and then to a main cross connect. There shall more than two hierarchical levels of cross-connects in the backbone cabling.

Backbone Cabling Distances: The use of UTP Cables above 5 MHz should be limited to a total distance of 90 mtrs only.

Main Cross-Connect (MC) to Entrance Point (EP): The distance between the entrance point and the main cross-connect shall be included in the total distance calculation.

Cross Connections: In the main cross-connect; jumper and patch cord lengths should not exceed 20 mtrs. In the intermediate cross-connect, jumper and patch cord lengths shall not exceed 20 mtrs.

Cabling to Telecommunication Equipment: Telecommunication equipment that connects directly to main or intermediate cross-connects should do via cables 30 mtrs or less.

1. Recognition Cables in the Backbone Cabling Sub-System:

1. 100 Ohms UTP cable
2. 62.5/125 µm optical fiber cable
3. Single-mode optical fiber cable
4. 50/125 µm optical fiber cable

Multipair cable is allowed provided it satisfies the power sum cross-talk requirements. Some points specified for the horizontal cabling sub-system.

1. Systems that are designed for non-star configurations such as ring, bus or tree shall be accommodated through the use of appropriate interconnections, electronics or adapters.
2. If requirements for "bus" or "ring" configurations are anticipated, cabling directly between telecommunication closets is allowed.

Work area

The work area components extend from the telecommunication outlet/connector end of the horizontal cabling systems to the station equipment.

Standards Overview

Telecommunication Closets

The primary function of a telecommunication closet is for the termination of horizontal cable distribution. Horizontal cables of all recognition types are terminated in the telecommunications closet on compatible connecting hardware. The cross-connection of horizontal and backbone cable terminated using jumpers or patch cards allows flexible connectivity when extending various servicing to telecommunication outlets/connectors. Connection hardware, jumpers and patch cords used for this purpose are collectively referred as "horizontal cross connects"

Equipment Rooms

An equipment room provides a controlled environment to house telecommunication equipment, connecting hardware, splice closures, grounding and bonding facilities and protection apparatus.

Entrance Facilities

The entrance facility consists of the cables, connecting hardware, protection devices and other equipment needed to connect the outside facilities to premises cabling. The demarcation point between the carrier/services providers and the customer premises cabling is a part of the entrance facility.

Glossary

A

ATM - Asynchronous Transfer Mode A very high-speed transmission technology, ATM features high bandwidth, low delay, packet-like switching and multiplexing Utilizes fixed-size cells with header and information fields.

Amplitude - The distance between high or low points of a waveform or signal. Also referred to as wave" height".

Attenuation - Loss of volume during transmission, or decrease in the power of a signal, light beam, or light wave Measured in decibels Opposite of gain.

AWG - American Wire Gauge. Standard measuring gauge for nonferrous conductors (ie, non-iron and non-steel) Gauge measures the diameter of a conductor (thickness of cable).

B

Backbone Wiring - The physical/electrical interconnections between telecommunications closets and equipment rooms. Cross-connect hardware and cabling in the Main and Intermediate Cross-Connects are considered part of the backbone wiring.

Bandwidth - The difference between the highest and the lowest frequencies of a transmission channel (path for information transmission) Identifies the amount of data that can be sent through a given channel Measured in Hertz (Hz); higher bandwidth numbers mean higher data capacity.

Bend Radius (Fiber) - Radius of curvature that a fiber can bend without breaking also see Cable Bend Radius.

BICSI - (Building Industry Consulting Service International) BICSI is a non-profit professional association, for the promotion of telecom industry standards.

Bit Error Rate (BER) - In digital applications, the percentage of bits received in error to the total number of bits received usually expressed as a number to the power of 10. For example 10 to the fifth power means that one in every 100,000 bits transmitted will be wrong.

Buffer Coating - Protective material coating applied to fibers Stated in microns.

Bus - A network topology in which nodes are connected to a single cable with terminations at each end.

C

Cable Assembly - A fixed length of cable with connectors installed on both ends. Sometimes called a Patch Cord, or Patch Cable.

Cable Bend Radius - The amount of bend that can occur before a cable may sustain damage or increased attenuation.

Category 3 - CAT3, A Category of Performance for inside wire and cable systems. Commonly used for voice applications and data to 10Mbps. Defined by FCC Part 68, ANSI/EIA/TIA-568, TIA TSB-36 and TIA TSB-40.

Category 5 - CAT5, A Category of Performance for inside wire and cable systems. Used in support of voice and data applications requiring a carrier frequency of up to 100 MHz. Defined by FCC Part 68, EIA/TIA-568, TIA TSB-36 and TIA TSB-40.

Category 5e (Enhanced) - CAT5e, A Category of Performance for inside wire and cable. Used in support of signalling rates of up to 100MHz over distances of up to 100 meters. Calls for tighter twists, electrical balancing between pairs and fewer cable anomalies CAT 5e is intended to support 1 00 Base-T, ATM and Gigabit Ethernet Currently the most common cabling being installed for LAN connectivity.

Category 6 - Cat6, A cable standard for Unshielded Twisted Pair (UTP) supporting signaling rates up to 250 MHz. Applications include 1000Base-T, ATM, Gigabit Ethernet and applications under development.

Category of Performance - Cabling and cabling component standard adopted by the telecommunications industry.

Cladding - The transparent material, usually glass, that surrounds the core of an optical fiber, causing any dispersed light to be reflected back into the central core, thereby helping to maintain signal strength over long distances.

Cleaving - To cut the end of fiber at 90 degrees with as few rough edges as possible before a fiber termination.

CO - Central Office. Telephone company facility where subscribers' lines are joined to switching equipment for connection to each other, locally and long distance Sometimes the same as the overseas term "public exchange".

Coaxial Cable - A cable composed of an insulated central conducting wire wrapped in another cylindrical conductor (the shield) The whole thing is usually wrapped in another insulating layer and an outer protective layer A coaxial cable has great capacity to carry vast quantities of information. It is typically used in high-speed data and CATV applications.

Compliance - A wiring device that meets all characteristics of a standard is said to be in compliance with that standard.

Conductor - Any substance, usually a wire or cable, that can carry an electrical current.

Connecting Block - Also called a terminal block, punch-down block, quick-connect block, or cross-connect block A plastic block containing metal wiring terminals to establish connections from one group of wires to another Usually each wire can be connected to several other wires in a bus or common arrangement There are several types of connecting blocks 66 clip, BIX, Krone, 110, etc A connecting block has insulation displacement connections (IDCs), which means you don't have to remove insulation from around the wire conductor before you "punch it down" (terminate it).

Connector - A device that connects wires or fibers in cable to equipment or other wires or fibers Wire and optical connectors most often join transmission media to equipment or cross connects A connector at the end of a telephone cable or wire is used to join that cable to another cable with a mating connector or to some other telecommunications device Note Connectors are sometimes a referred to as jacks, but though all jacks are connectors, not all connectors are jacks.

Cross-connect - Distribution system equipment used to terminate and administer communication circuits In a wire crossconnect, jumper wires or patch cords are used to make circuit connections In an optical cross-connect, fiber patch cords are used. The cross-connect is located in an equipment room, riser closet, or satellite closet.

Crosstalk - See Near-End Crosstalk.

D

Daisy Chain - In telecommunications, a wiring method where each telephone Jack in a building is wired in series from the previous Jack Daisy chain is NOT the preferred wiring method, since a break in the wiring would disable all jacks "downstream" from the break See also Home Run.

dB (Decibel) - A dB is a unit of measure of signal strength, usually the relation between a transmitted signal and a standard signal source Every 3dB equals 50% of signal strength, so therefore a 6dB loss is a loss of 75% of total signal strength.

Demarcation Point -The point of interconnection between telephone company terminal equipment and your building wiring. The protective apparatus or wiring at a subscriber's premises.

Device - As distinguished from equipment In telecommunications, a "device" is the physical interconnection outlet Equipment (a computer, phone, fax machine, etc) then plugs Into the device. See also Equipment and Plug.

Drop Wire - Outside wire pair(s) from the telco plant (cable), to a house or building for connection to a protector.

DTMF - Acronym for Dual Tone, Multi-Frequency See Tone Dial.

E

EIA - Electronic Industries Alliance A trade organization of manufacturers which set standards for use of its member companies Many associations fall under the umbrella of EIA, though it has recently been absorbed by the TIA, or Telecommunications Industry Association See www.eia.org or www.tiaonline.org.

Electromagnetic Interference (EMI) - The Interference in signal transmission or

reception caused by the radiation of electrical and magnetic fields.

Equipment - As distinguished from Device Telecom equipment (computers, phones, faxes, etc. plugs into telecommunications outlets or devices See also Device.

Epoxy Connector - A type of fiber Optic connector that requires a chemical bond, or epoxy.

Ethernet - Type of local area network used for connecting computers, printers, workstations, terminals, etc within the same building Ethernet is a physical link and data link protocol that operates over twisted pair wire and over coaxial cable at speeds up to 10Mbps Ethernet LANs are being promoted by DEC, Intel and Xerox. Compare with Token Ring.

F

Ferrule - A component of a fiber optic connection that holds a fiber in place and aids in its alignment.

Fiber Optics - A technology in which light is used to transport information from one point to another More specifically, fiber optics are thin filaments of glass through which light beams are transmitted over long distances carrying enormous amounts of data.

H

Headroom (also called Overhead or Margin) - The number of decibels by which a system exceeds the minimum defined requirements. The benefit of headroom is that it reduces the bit error rate (BER), and provides a performance 'safety net' to help ensure that current and future high speed applications will run at peak accuracy, efficiency and throughput.

Home Run - Telephone system wiring where the individual cables run from each telephone directly back to the central switching equipment Home run cabling can be thought of as "star" cabling Every cable radiates out from the central equipment All PBXs and virtually all key systems work on home run cabling Some local area networks work on home run wiring See also Star Wiring, Daisy Chain.

Hub - The point on a network where circuits are connected Also, a switching node. In local area networks, a hub is the core of a star as in ARCNET, StarLAN, Ethernet, and Token Ring Hub hardware can be either active or passive Wiring hubs are useful for their centralized management capabilities and for their ability to isolate nodes from disruption.

Hybrid Connector - A connector containing both optical fiber and electrical conductors.

I

Insertion Loss - The difference in the amount of power received before and after something is inserted into the circuit In optical fiber, insertion loss is the optical power loss due to all causes, usually expressed as decibel/kilometer.

IDC (Insulation Displacement Connection) - A type of wire termination where wire is "punched down" into a metal holder which cuts into the insulation wire and makes contact with the conductor, causing the electrical connection to be made.

IDF (Intermediate Distribution Frame) - A metal rack designed to connect cables and located in an equipment room or closet Consists of components that provide the connection between inter-building cabling and the intra-building cabling, ie between the Main Distribution Frame (MDF) and individual telephone wiring. There's usually a permanent, large cable running between the MDF and IDF The changes in wiring are done at the IDF This saves confusion in wiring.

IEEE 802.3 - IEEE stands for the Institute of Electrical and Electronic Engineers, a publishing and standards-making body responsible for many standards used in LANs, including the 802 series Ethernet and StarLan both follow the 802.3 standard Typically they transmit at 10 megabits per second This is the most common local area network specification.

Impedance - The total opposition (ie resistance and reactance) a circuit offers to the flow of alternating current It is measured in ohms, and the lower the ohmic value, the better

the quality of the conductor.

Interconnect -

1. A circuit administration point, other than a cross-connect or an information outlet, that provides capability for routing and rerouting circuits It does not use patch cords or jumper wires, and typically is a jack-and-plug device used in smaller distribution arrangements or that connects circuits in large cables to those in smaller cables

2. An Interconnect Company is one which sells, installs, and maintains telephone systems for end users, typically businesses.

ISDN - Integrated Services Digital Network. According to AT&T, today's public switched phone network has many limitations; ISDN's vision is to overcome these deficiencies.

J

Jack - A receptacle used in conjunction with a plug to make electrical contact between communication circuits Jacks and their associated plugs are used for connecting hardware applications Including cross connects, interconnects, information outlets, and equipment connections Jacks are used to connect cords or lines to telephone systems A jack is the female component of a plug/jack connector system, and may be standard, modified, or keyed.

Jacket - Also Cable Jacket or Sheath The outer covering applied over internal cable elements for protection.

L

LAN - Local Area Network A short distance network (typically within a building or campus) used to link together computers and peripheral devices (such as printers) under some form of standard control.

Loop - 1 Typically a complete electrical circuit 2 The loop is also the pair of wires that winds its way from the central office to the telephone set or system at the customer's office, home or factory (ie, 'premises' in telephony terms).

M

Mbps - Megabits Per Second One million bits per second. (Different from Mbps, or a million bytes per second.)

MDF - Main Distribution Frame A wiring arrangement which connects the telephone lines coming from outside on one side and the internal lines on the other A main distribution frame may also carry protective devices as well as function as a central testing point.

Mhz - Megahertz A unit of frequency denoting one million Hertz (ie, 1,000,000 cycles per second).

Micron - One thousandth of a millimeter, or one millionth of a meter Can be used to specify the core diameter of fiber-optic network cable.

MMJ - Modified Modular Jack A six-wire modular Jack with the locking tab shifted off to the right side Used In the DEC wiring system.

Modular - Equipment is said to be modular when it IS made of "plug-in units" which can be added together to make the system larger, improve the capabilities, or expand its size.

MT-RJ - A small form factor fiber optic connector that is defined by its high density footprint and RJ47 locking mechanism.

Multimode - Optical fiber with either 50 micron or 625 micron core size, designed to allow light to carry multiple signals distinguished by frequency or phase, at the same time can be used with LED or LASER light sources Contrasts with single-mode Common in Local Area Networks.

N

Nanometer - One billionth of a meter, abbreviated nm The nano~ meter is a convenient unit for describing the wavelength of light.

Near-End Crosstalk (NEXT) - Electrical noise coupled from one pair of wires to

another within a multi-pair cable.

Network - A network ties things together. Computer networks connect all types of computers and computer-related things terminals, printers, modems, door entry sensors, temperature monitors, etc. The networks we're most familiar with are long distance ones, like telephones and trains. Local Area Networks (LANs) connect computer equipment within a building or campus.

O

Open (Fault) - Means that the circuit is not complete or the cable/fiber is broken.

Outlet - A telecommunications outlet is a single-piece cable termination assembly (typically on the floor or in the wall), containing one or more modular telecom jacks. Such jacks might be RJ's, coaxial terminators, fiber optic couplers, etc. See also Device and Equipment.

P

Part 68 Requirements - Specifications established by the FCC as the minimum acceptable protection communications equipment must provide the telephone network.

Patching - A means of connecting circuits via cords and connectors that can be easily disconnected and reconnected at another point. May be accomplished by using modular cords connected between jack fields or by patch cord assemblies that plug onto connecting blocks.

PBX - Private Branch Exchange. A small, privately-owned version of the phone company's larger telephone central switching office.

Performance - Compare with Compliance. A device can exhibit performance characteristics without being compliant to an industry standard.

Plug - A male component of a plug/jack connector system. In premises wiring, a plug provides the means for a user to connect communications equipment to the communications outlet.

Polarity - Which side of an electrical circuit is the positive? Which is the negative? Polarity is the term describing which is which.

POTS - Plain Old Telephone Service. The basic service supplying standard single line telephones, telephone lines and access to the public switched network. Just receive and place calls. No added features like Call Waiting or Call Forwarding.

Power Sum - A test method for four pair cable whereby the mathematical sum of pair-to-pair crosstalk from three pairs to one pair is measured.

Premise - Telephony term for the space occupied by a customer or authorized/joint user in a building(s) on continuous or contiguous property (except railroad rights of way, etc) not separated by a public road or highway.

Premises Wiring System - The entire wiring system on the user's premises, especially the supporting wiring that connects the communications outlets to the network interface jack.

R

RBOC - Regional Bell Operating Company. Seven RBOCs exist, each of which owns two or more Bell Operating Companies (BOCs). The RBOCs were carved out of the old AT&T/Bell System during the divestiture of the Bell operating companies from AT&T in 1984.

RCDD - The RCDD (Registered Communications Distribution Designer) title is a professional rating granted by BICSI (the Building Industry Consulting Service International). RCDDs have demonstrated a superior level of knowledge of the telecommunications wiring industry and associated disciplines.

Return Loss - A measure of the similarity of the impedance of a transmission line and the impedance at its terminations. It is a ratio, expressed in decibels, of the power of the outgoing signal to the power of the signal reflected back.

Ring - As in Tip and Ring. One of the two wires needed to set up a telephone connection. See Tip.

RJ - Registered Jack. RJ's are telephone and data jacks/applications registered with the FCC Numbers, like RJ-11, RJ-45, etc. are widely misused in the telecommunications industry. A much more precise way to identify a jack is to specify the number of positions (width of opening) and number of conductors. Example: "8-position, 8-conductor jack" or "6-position, 4-conductor jack".

S

Series Wiring - See Daisy Chain.

Service Loop - When a device is terminated to the wire in the communications outlet, a fair amount of "slack" should be left on the wire and wound in the box to accommodate future trimming when devices are changed out.

Single-mode - Optical fiber with an 83-95 micron core size, optimized for LASER light sources which transmit only one mode or path of light. This eliminates modal dispersion, the main limitation to bandwidth. Typical in long-haul networks and outside plant applications due to increased bandwidth.

Splice - The joining of two or more cables together by connecting the conductors pair-to-pair.

Standards - Agreed principles of protocol. Standards are set by committees working under various trade and international organizations.

Star Wiring/Star Topology - See Home Run.

T

T1 - A standard for digital transmission in North America. A digital transmission link with a capacity of 1.544 Mbps (1,544,000 bits per second). T1 lines are used for connecting networks across remote distances. Bridges and routers are used to connect LANs over T1 networks.

Talk Battery - The DC voltage supplied by the central office to the subscriber's loop, which allows voice conversation.

TCP/IP - A set of protocols developed by the department of the defense to link dissimilar computers across many kinds of networks.

Telco - An Americanism for Telephone Company.

Ten Base-T-See 1 Obase - T at end of Glossary.

Terminate - To connect a wire conductor to something, typically a piece of equipment.

TIA - Telecommunications Industry Association. A trade organization of manufacturers which sets standards for use of its member companies. Formerly fell under the umbrella of EIA, (Electronic Industries Alliance). See www.tiaonline.org.

Tip - 1. The first wire in a pair of wires (The second wire is called the "Ring" wire)

2. A conductor in a telephone cable pair which is usually connected to positive side of a battery at the telco. It is the telephone industry's equivalent of Ground in a normal electrical circuit. See Ring.

Tone Dial - A push-button telephone dial that makes a different sound (in fact, a combination of two tones) for each number pushed. The technically correct name for tone dial is Dual Tone Multi Frequency, or DTMF.

Token Ring - A ring topology for a local area network (LAN) in which a supervisory frame, or token, must be received by an attached terminal or workstation before that terminal or workstation can start transmitting. The workstation with the token then transmits and uses the entire bandwidth of whatever communications media the token ring network is using.

A token ring can be wired as a circle or a star, with the workstations wired to a central wiring center, or to multiple wiring centers. The most common wiring scheme is called a starwired ring. Whatever the wiring, a token ring LAN always works logically as a circle, with the token passing around the circle from one workstation to another.

The advantage of token ring LANs is that media faults (broken cable) can be fixed easily, since it's easy to isolate the faults. Token rings are typically installed in centralized closets, with loops snaking to served workstations.

Topology - As in network topology The geometric physical or electrical configuration describing a local communication network; the shape or arrangement of a system The most common topologies are the bus, ring and star.

TP-PMD - Twisted Pair-Physical Media Dependent. Technology under review by the ANSI X3T95 working group that allows 1 00Mbps transmission over twisted-pair cable.

Twisted Pair - Two insulated copper wires twisted around each other to reduce induction (thus interference) from one wire to the other. The twists, or lays, are varied in length to reduce the potential for signal interference between pairs. Several sets of twisted pair wires may be enclosed in a single cable. In cables greater than 25 pairs, the twisted pairs are grouped and bound together.

U

UL - Underwriters Laboratories, a privately owned company that tests to make sure that products meet safety standards. UL also administers a program for the certification of Category-Rated Cable.

USOC - Universal Service Order Code An old Bell system term identifying a particular service or equipment offered under tariff.

UTP - Unshielded Twisted Pair See Twisted Pair.

W

Workstation - The working area in a building required by one telecommunications user. Industry standards call for one voice drop and one data drop for each workstation. The voice drop is one 4-pair unshielded twisted pair (UTP). The data drop may be 100 4-pair UTP, 150 2-pair shielded twisted pair (STP), or optical fiber.

10BASE-T - This is the IEEE standard that defines the requirement for sending information at 1 0Mbps over unshielded twisted-pair cabling, and defines various aspects of running Ethernet on this cabling.

100BASE-T - This is the IEEE standard that defines the requirement for sending information at 1 00Mbps over unshielded twisted-pair cabling, and defines various aspects of running baseband Ethernet on this cabling.

1000BASE-T - This is the IEEE standard that defines the requirement for sending information at 1000Mbps over unshielded twisted-pair cabling, and defines various aspects of running baseband Ethernet on this cabling.

10GBASE-T - This is the proposed IEEE standard that defines the requirement for sending information at 10 GMbps over unshielded twisted-pair cabling, and defines various aspects of running baseband Ethernet on this cabling.

About Schneider Electric

As the global specialist in energy management with operations in more than 100 countries, Schneider Electric offers integrated solutions across multiple market segments, including leadership positions in energy and infrastructure, industrial processes, building automation, and data centres/networks, as well as a broad presence in residential applications. Focused on making energy safe, reliable, and efficient, the company's 110,000 plus employees achieved sales of 19.6 billion euros in 2010, through an active commitment to help individuals and organizations "Make the most of their energy".

The LifeSpace Business of Schneider Electric provides solutions that represent the best in lifestyle and innovation for offices, hotels and homes. These solutions include award-winning products in the areas of building and home automation, structured cabling, and designer switches and sockets. They help the finest architectures around the world to achieve more with less.

www.schneider-electric.com

